

Problem Set 1b - Large Signal Model

Question 1

Consider the following NMOS transistor with $\lambda = 0$

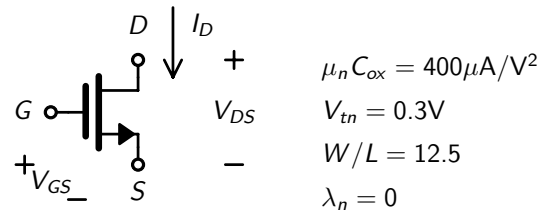

Assuming $V_{GS} = 0.55\text{V}$, answer the following questions...

- As V_{DS} is increased, at what value of V_{DS} does the transistor enter the saturation (active) region?
- What is the value of I_D in saturation

Answer

$$V_{DS} = 0.25\text{V}$$

$$I_D = 156.3 \mu\text{A}$$

Question 2

At what voltage of V_{in} does I_D start to be greater than zero?

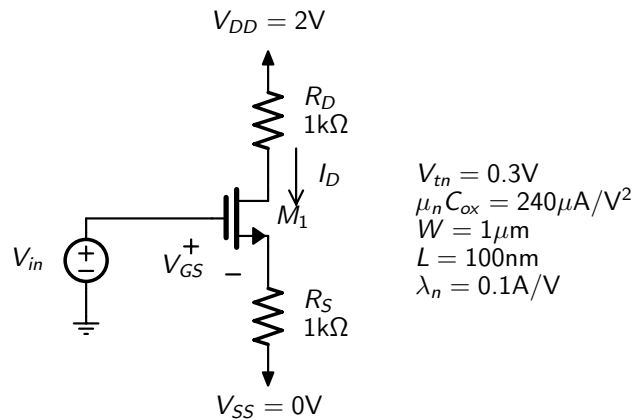

Answer

$$V_{in} > V_{tn} = 0.3\text{V}$$

Question 3

Find V_S , V_{GS} , V_{DS} and I_D for the circuit below.

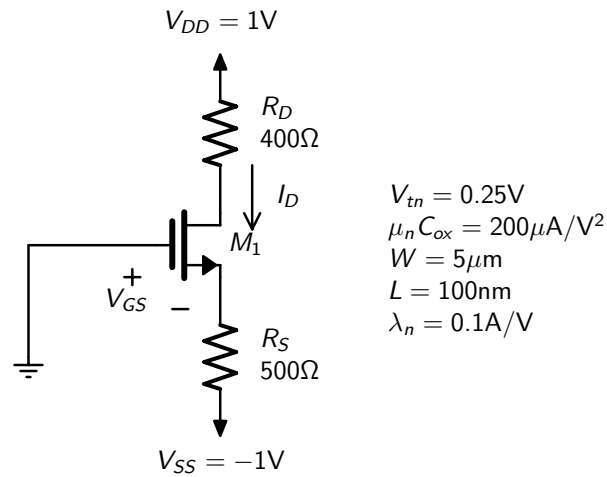
**Answer**

$$V_S = -0.6331V, V_{GS} = 0.6331V, V_{DS} = 1.34V, I_D = 733.8\mu A$$

Question 4

For the circuit below, choose values for R_D and R_S such that $I_D = 500\mu A$ and $V_D = 0.4V$

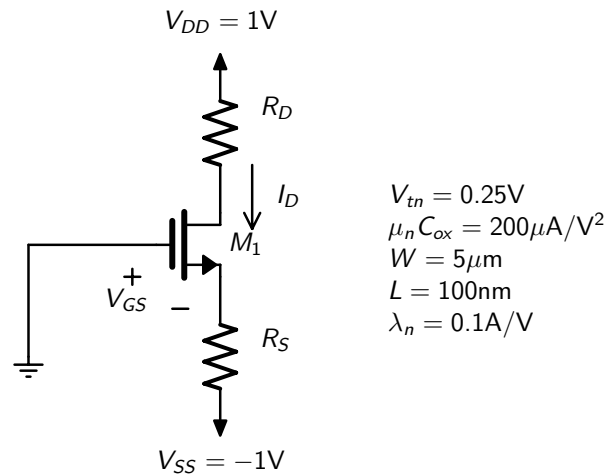
**Answer**

$$R_D = 1.2k\Omega, R_S = 867.5\Omega$$

Question 5

Find V_S , V_{GS} , V_{DS} and I_D for the circuit below.

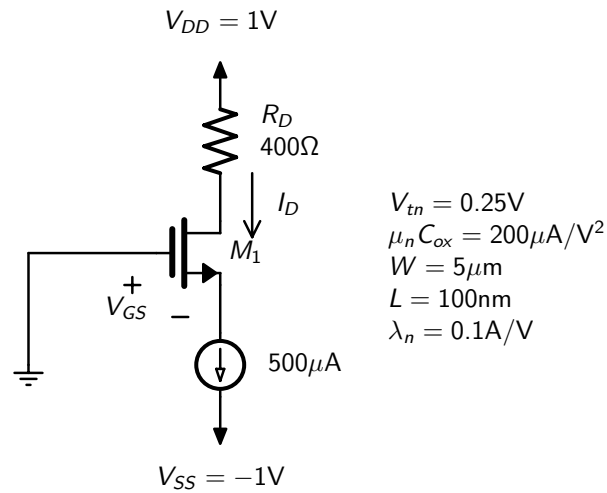

Answer

$$V_S = -0.5662V, V_{GS} = 0.5662V, V_{DS} = 1.366V, I_D = 500\mu A$$

Question 6

Find V_S , V_{SG} , V_{SD} and I_D for the circuit below.

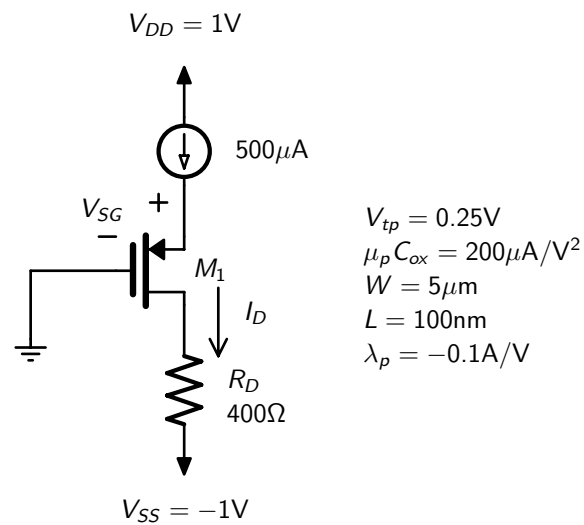

Answer

$$V_S = 0.5662V, V_{SG} = 0.5662V, V_{SD} = 1.366V, I_D = 500\mu A$$

Question 7

In a CMOS technology, it is found that $\mu_p = 0.3\mu_n$ and C_{ox} is the same for NMOS and PMOS transistors. (It is often the case that C_{ox} is the same for NMOS and PMOS transistors in the same technology)

Find the relative width W_p/W_n for a PMOS transistor such that the PMOS transistor and NMOS transistor have the same current when both are in the active region and have the same overdrive voltage. Assume both transistors have the same length and that $\lambda = 0$ for both.

Answer

$$\frac{W_p}{W_n} = 3.333$$
