

Problem Set 1b - Large Signal Model

Question 1

Consider the following NMOS transistor with $\lambda = 0$

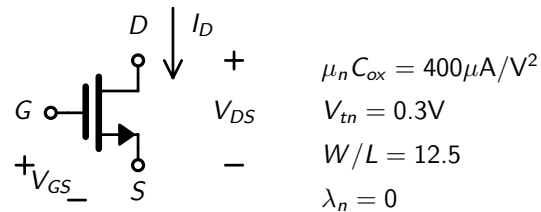

Assuming $V_{GS} = 0.55\text{V}$, answer the following questions...

- (a) As V_{DS} is increased, at what value of V_{DS} does the transistor enter the saturation (active) region?
 (b) What is the value of I_D in saturation

Solution

For an NMOS transistor, the overdrive voltage is

$$V_{OV} = V_{GS} - V_{tn} = (0.55) - (0.3) = 0.25\text{V}$$

When $V_{DS} < V_{OV}$, the transistor is in the triode region. The transistor enters the saturation region when

$$V_{DS} = V_{DSsat} = V_{OV} = (0.25) = 0.25\text{V}$$

Once in saturation, the drain current is given by

$$I_D = 0.5 * \mu_n C_{ox} * W/L * V_{OV}^2 = 0.5 * (400e-6) * (12.5) * (0.25)^2 = 156.3 \mu\text{A}$$

Question 2

At what voltage of V_{in} does I_D start to be greater than zero?

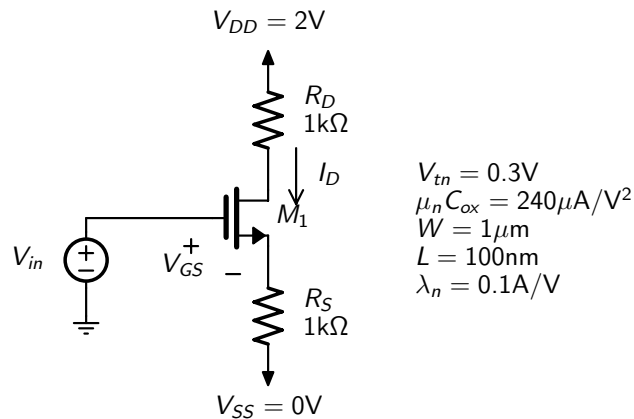

Solution

For $V_{in} = 0$, $V_{GS} = 0$ and the transistor is in cutoff with $I_D = 0$.

When $V_{in} = V_{tn}$, then $V_{GS} = V_{tn}$ and I_D still equals zero but at any higher V_{in} voltage, then I_D will be non-zero.

So a voltage of $V_{in} > V_{tn} = 0.3V$, I_D will be greater than zero.

Question 3

Find V_S , V_{GS} , V_{DS} and I_D for the circuit below.

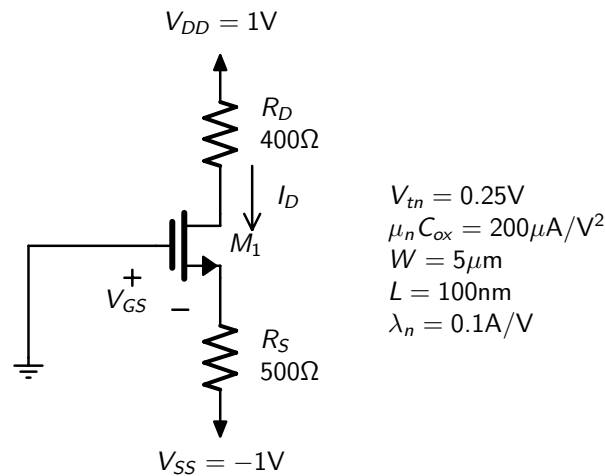

Solution

Assume the transistor is in the active region and also let $\lambda_n = 0$. Recall $V_{GS} = V_{ov} + V_{tn}$. We have 2 equations

$$I_S = \frac{-(V_{ov} + V_{tn}) - (V_{SS})}{R_S}$$

$$I_S = I_D = 0.5\mu_n C_{ox} (W/L) (V_{ov})^2$$

Putting in values, we have

$$I_S = 0.0015 - 0.002V_{ov}$$

$$I_S = 0.005V_{ov}^2$$

and combining the above 2 equations and rearranging we have

$$V_{ov}^2 + 0.4V_{ov} - 0.3 = 0$$

The above is a quadratic equation of the form $ax^2 + bx + c = 0$. The roots of a quadratic equation are found to be

$$x = \frac{-b \pm \sqrt{b^2 - 4ac}}{2a}$$

Using the above quadratic equation solution results in 2 values for V_{ov} : 0.3831V and $-0.7831V$. However, we know that $V_{ov} > 0$ so the solution is $V_{ov} = 0.3831V$.

$$V_{GS} = V_{ov} + V_{tn} = (0.3831) + (0.25) = 0.6331V$$

$$I_D = k_3 * (V_{ov})^2 = (5e-3) * ((0.3831))^2 = 733.8\mu A$$

Now we need to check that $V_{DS} \geq V_{ov}$ to ensure the device is in the active region.

$$V_S = -V_{GS} = -(0.6331) = -0.6331\text{V}$$

$$V_D = V_{DD} - I_D * R_D = (1) - (733.8e - 6) * (400) = 0.7065\text{V}$$

$$V_{DS} = V_D - V_S = (0.7065) - (-0.6331) = 1.34\text{V}$$

So $V_{DS} = 1.34\text{V}$ is indeed greater than $V_{ov} = 0.3831\text{V}$

So everything is consistent with M_1 being in the active region and the final results are:

$$V_S = -0.6331\text{V}, V_{GS} = 0.6331\text{V}, V_{DS} = 1.34\text{V} \text{ and } I_D = 733.8\mu\text{A}.$$

Question 4

For the circuit below, choose values for R_D and R_S such that $I_D = 500\mu\text{A}$ and $V_D = 0.4\text{V}$

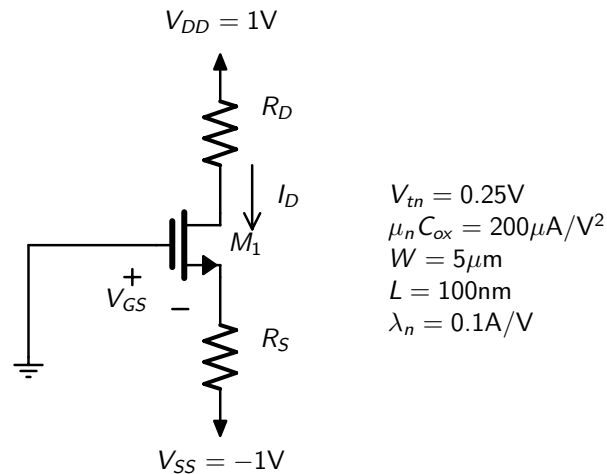

Solution

Since $V_D = 0.4\text{V}$ and $I_D = 500\mu\text{A}$, we can find the value of R_D from

$$I_D = (V_{DD} - V_D)/R_D$$

$$R_D = (V_{DD} - V_D)/I_D = ((1) - (0.4))/(500e - 6) = 1.2\text{k}\Omega$$

To find R_S , we first find V_{ov} from the equation (assume $\lambda_n = 0$ as discussed above)

$$I_D = 0.5\mu_n C_{ox}(W/L)(V_{ov})^2$$

$$500\mu\text{A} = 0.005V_{ov}^2$$

$$V_{ov} = \sqrt{500\mu\text{A}/5e - 3} = 0.3162\text{V}$$

(We take the positive root since $V_{ov} \geq 0$)

$$V_{GS} = V_{ov} + V_{tn} = (0.3162) + (0.25) = 0.5662\text{V}$$

and since $V_G = 0$ then $V_S = -0.5662\text{V}$

So now we can find R_S from

$$I_S = I_D = (V_S - V_{SS})/R_S$$

$$R_S = (V_S - V_{SS})/I_D = ((-0.5662) - (-1))/(500e - 6) = 867.5\Omega$$

and find V_{DS}

$$V_{DS} = V_D - V_S = (0.4) - (-0.5662) = 0.9662\text{V}$$

As a final check, we find $V_{DS} = 0.9662\text{V}$ and $V_{ov} = 0.3162\text{V}$. Since $V_{DS} \geq V_{ov}$, the transistor is in the active region as was assumed so there is no contradiction.

The final results are $R_D = 1.2\text{k}\Omega$ and $R_S = 867.5\Omega$

Question 5

Find V_S , V_{GS} , V_{DS} and I_D for the circuit below.

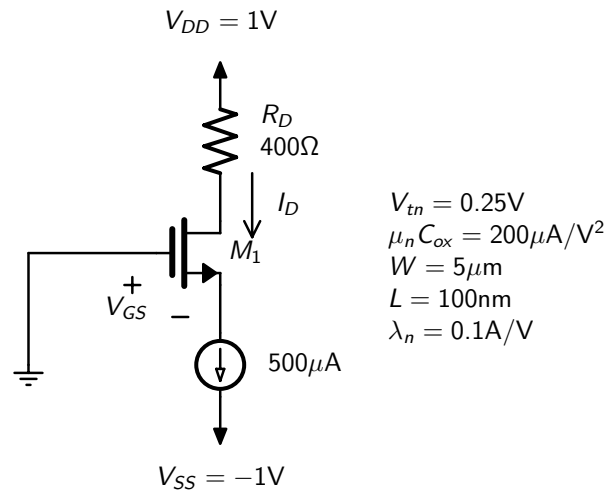

Solution

Since we see $I_S = 500\mu A$, and $I_D = I_S$, we have $I_D = 500\mu A$.

Now assuming the transistor is in the active region, we can write

$$I_D = 0.5\mu_n C_{ox} (W/L) (V_{ov})^2$$

we can write

$$500\mu A = 0.005 V_{ov}^2$$

$$V_{ov} = \sqrt{500\mu A / 5e-3} = 0.3162V$$

$$V_{GS} = V_{ov} + V_{tn} = (0.3162) + (0.25) = 0.5662V$$

and since $V_G = 0$ then $V_S = -0.5662V$

To find V_D , we have

$$V_D = V_{DD} - I_D R_D$$

$$V_D = V_{DD} - I_D * R_D = (1) - (500e-6) * (400) = 0.8V$$

resulting in

$$V_{DS} = V_D - V_S = (0.8) - (-0.5662) = 1.366V$$

Now we see that $V_{DS} > V_{ov}$ so everything is consistent with M_1 being in the active region and the final results are:

$$V_S = -0.5662V, V_{GS} = 0.5662V, V_{DS} = 1.366V \text{ and } I_D = 500\mu A.$$

Question 6

Find V_S , V_{SG} , V_{SD} and I_D for the circuit below.

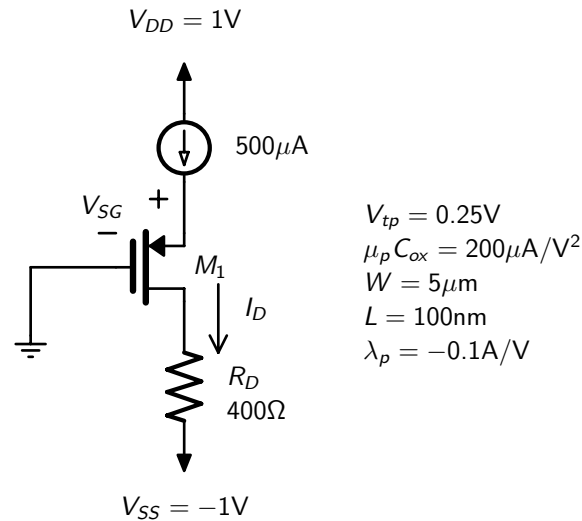

Solution

Since we see $I_S = 500\mu A$, and $I_D = I_S$, we have $I_D = 500\mu A$.

Now assuming the transistor is in the active region, we can write

$$I_D = 0.5\mu_p C_{ox} (W/L) (V_{ov})^2$$

we can write

$$500\mu A = 0.005 V_{ov}^2$$

$$V_{ov} = \sqrt{500\mu A / 5e-3} = 0.3162V$$

$$V_{SG} = V_{ov} + |V_{tp}| = (0.3162) + |(0.25)| = 0.5662V$$

and since we have $V_G = 0V$

$$V_S = V_G + V_{SG} = (0) + (0.5662) = 0.5662V$$

To find V_D , we have

$$V_D = V_{SS} + I_D R_D$$

$$V_D = V_{SS} + I_D * R_D = (-1) + (500e-6) * (400) = -0.8V$$

resulting in

$$V_{SD} = V_S - V_D = (0.5662) - (-0.8) = 1.366V$$

Now we see that $V_{SD} > V_{ov}$ so everything is consistent with M_1 being in the active region and the final results are:

$$V_S = 0.5662V, V_{SG} = 0.5662V, V_{SD} = 1.366V \text{ and } I_D = 500\mu A.$$

Question 7

In a CMOS technology, it is found that $\mu_p = 0.3\mu_n$ and C_{ox} is the same for NMOS and PMOS transistors. (It is often the case that C_{ox} is the same for NMOS and PMOS transistors in the same technology)

Find the relative width W_p/W_n for a PMOS transistor such that the PMOS transistor and NMOS transistor have the same current when both are in the active region and have the same overdrive voltage. Assume both transistors have the same length and that $\lambda = 0$ for both.

Solution

For an NMOS transistor in the active region

$$I_{Dn} = 0.5\mu_n C_{ox} (W_n/L_n) V_{OVn}^2$$

For a PMOS transistor in the active region

$$I_{Dp} = 0.5\mu_p C_{ox} (W_p/L_p) V_{OVp}^2$$

Setting $I_{Dn} = I_{Dp}$ and noting that $L_n = L_p$ and $V_{OVn} = V_{OVp}$, we can divide the 2 equations and find

$$1 = \frac{\mu_n W_n}{\mu_p W_p}$$

and rearranging we have

$$\frac{W_p}{W_n} = \frac{\mu_n}{\mu_p}$$

$$\frac{W_p}{W_n} = \frac{1}{0.3} = 3.333$$
