



All-Optical Wavelength Conversion on a Microchip

Sean J. Wagner
Photonics Group



UNIVERSITY OF
TORONTO



Motivation

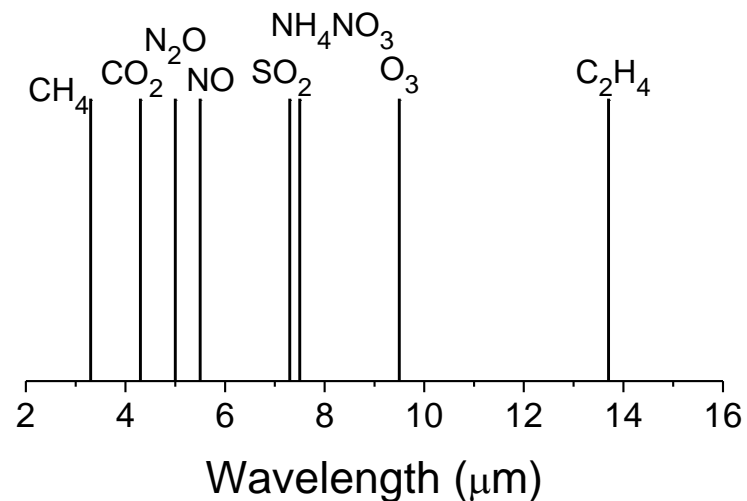
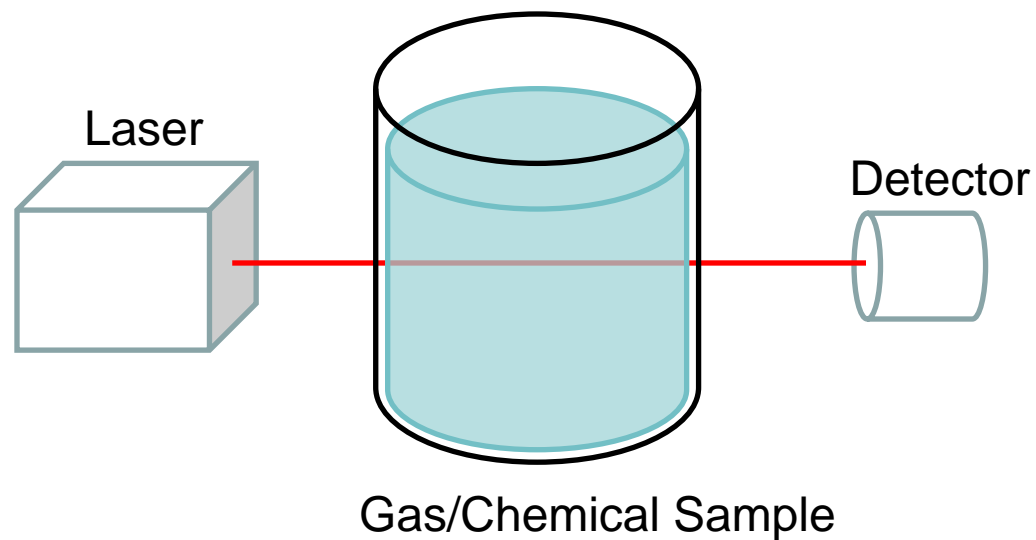

Chemical Analysis

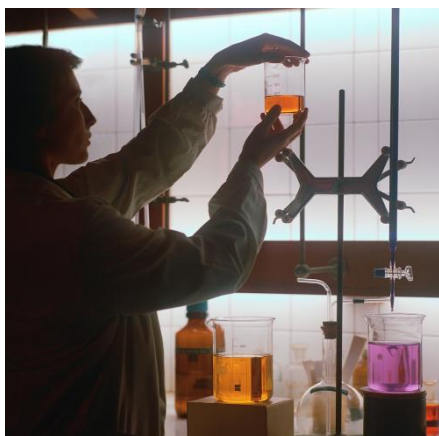

Security



Environmental Monitoring



Ultrafast Laser System



+

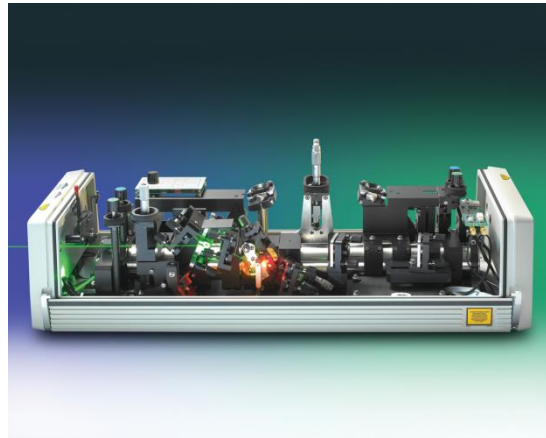

+



Quantum Cascade Lasers

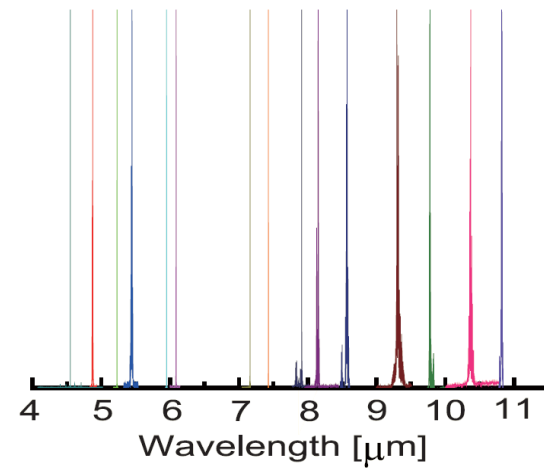
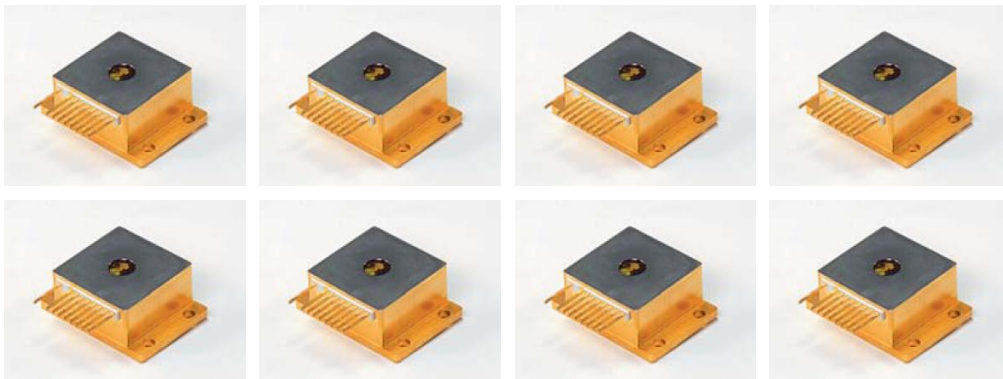

Single-Chip Converter

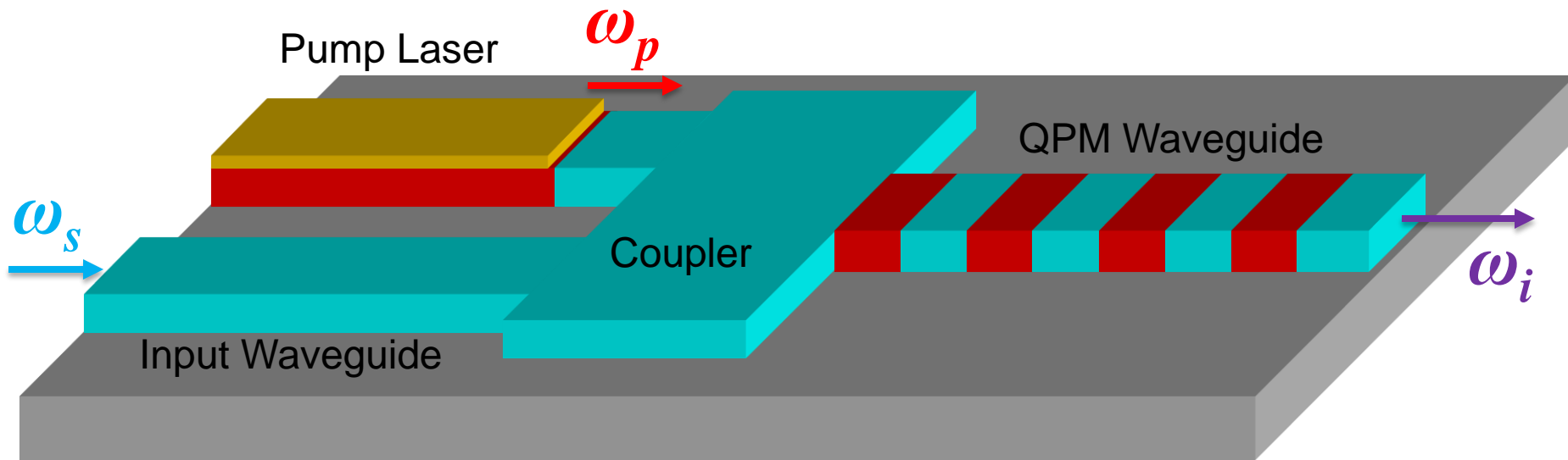

$$\omega_i = \omega_p - \omega_s$$

Phase Matching

Wave Mixing in Nonlinear Medium

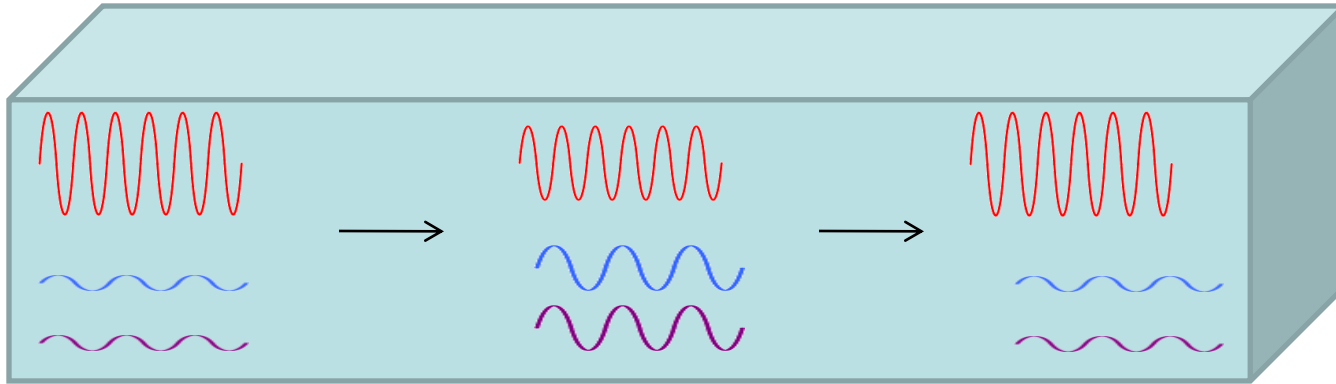

$$\omega_2 = \omega_3 - \omega_1$$

Solution: Quasi-Phase Matching

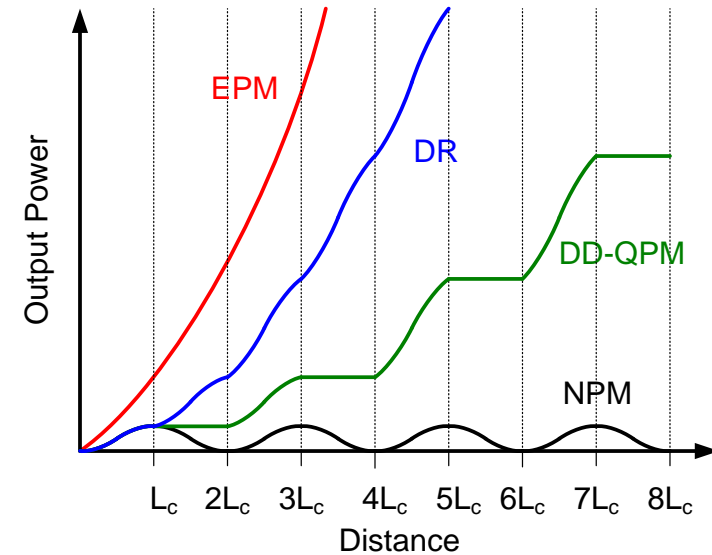

Fabrication Process

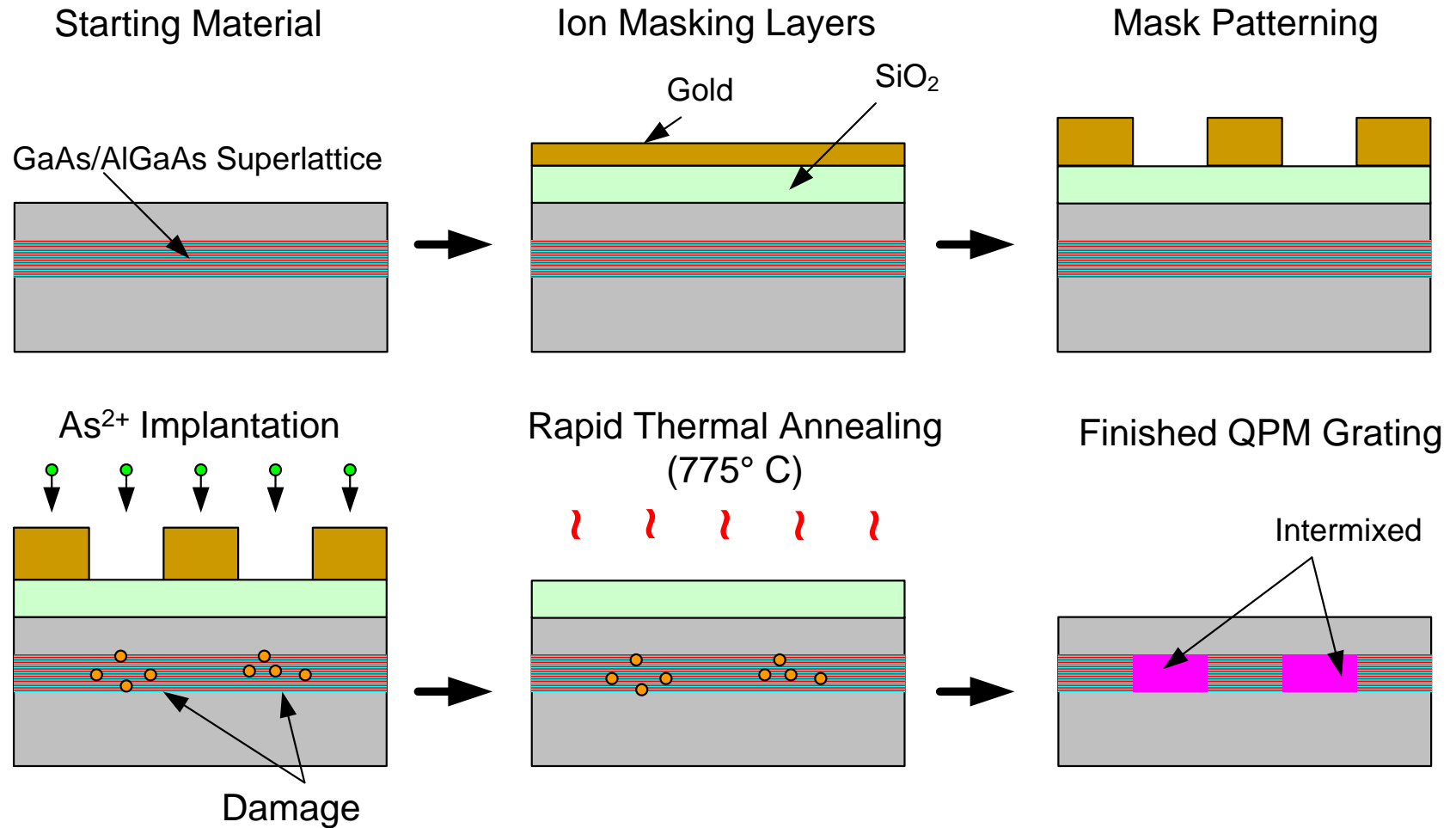

Fabricated Waveguides

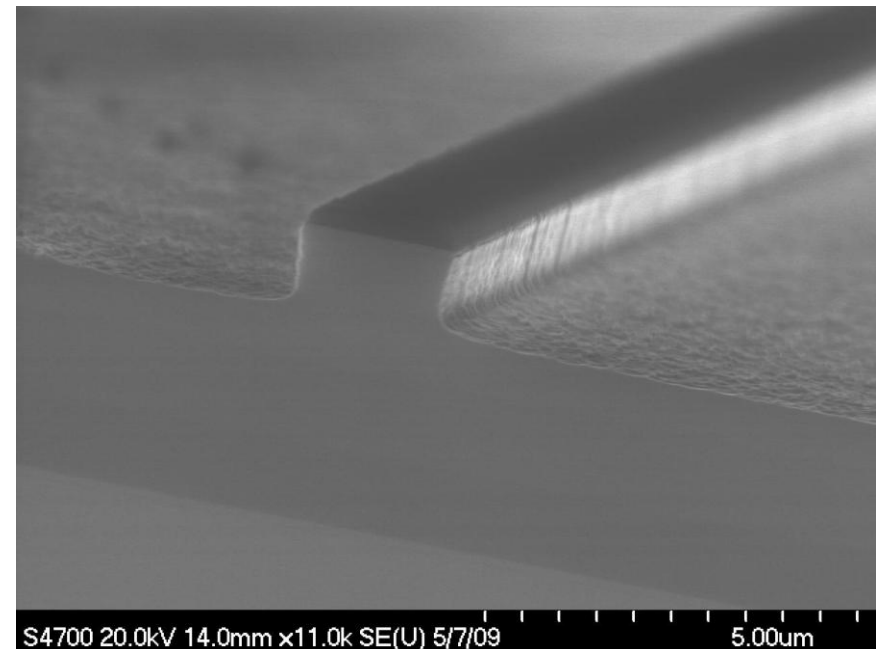
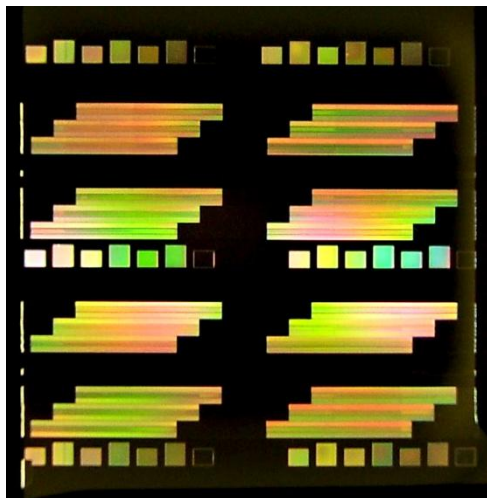
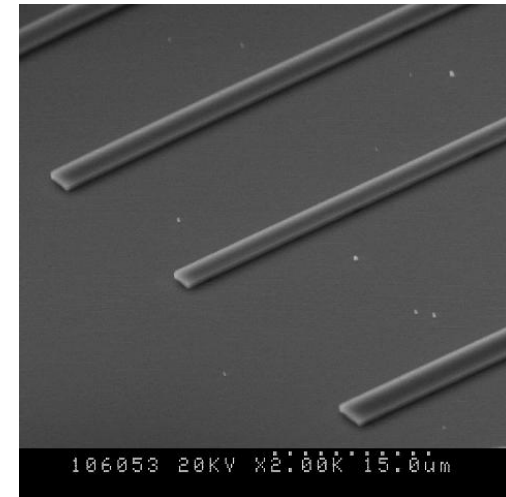
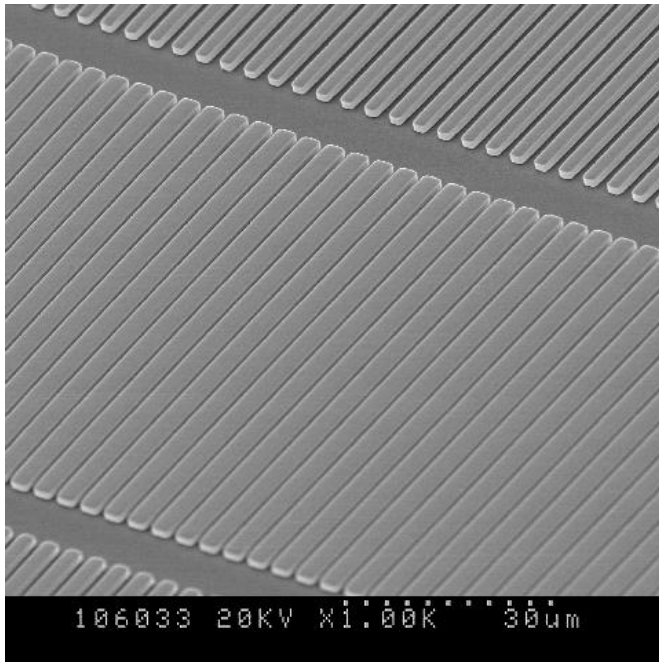

Conversion Experiment

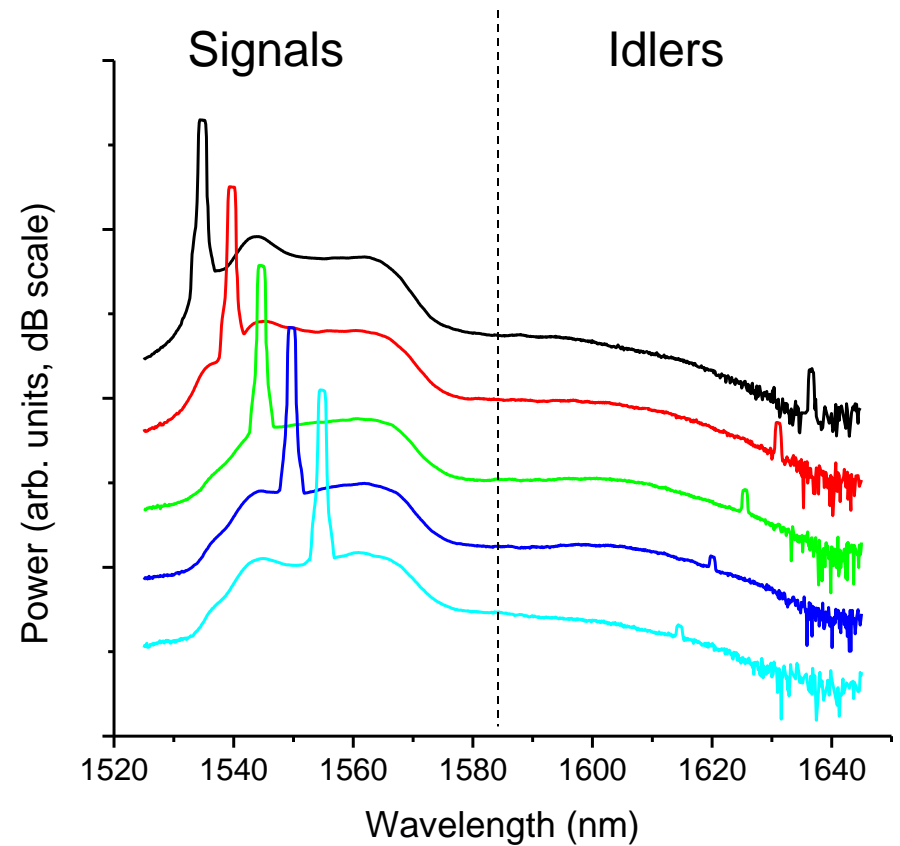
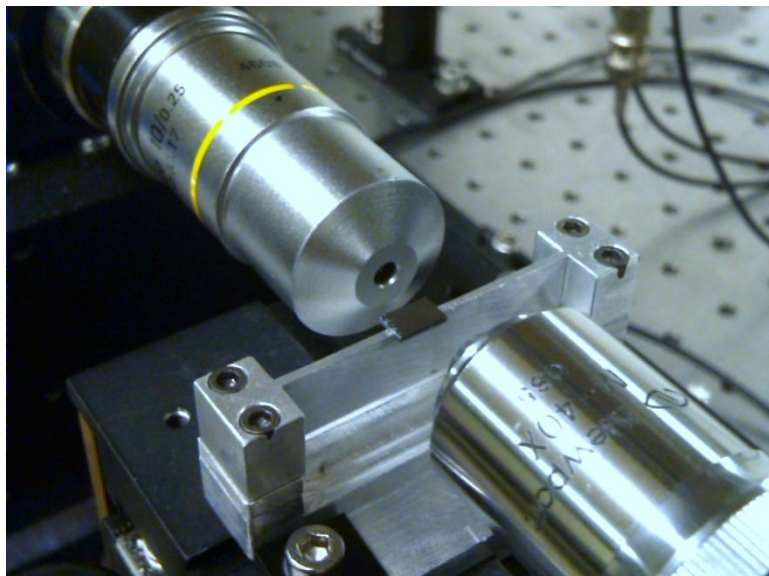
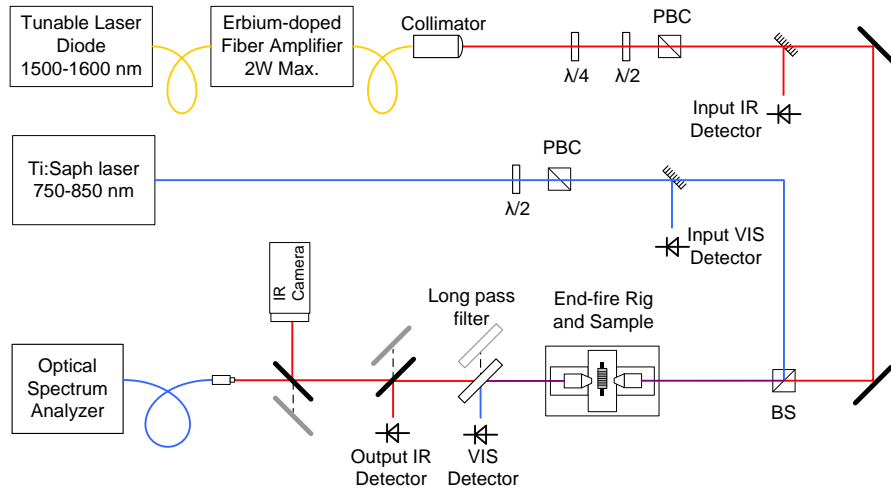

Superlattice Laser

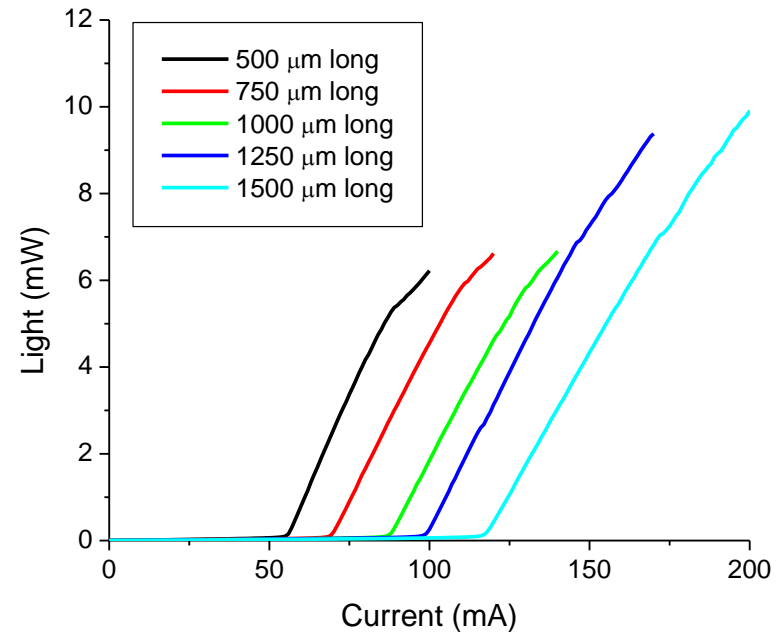
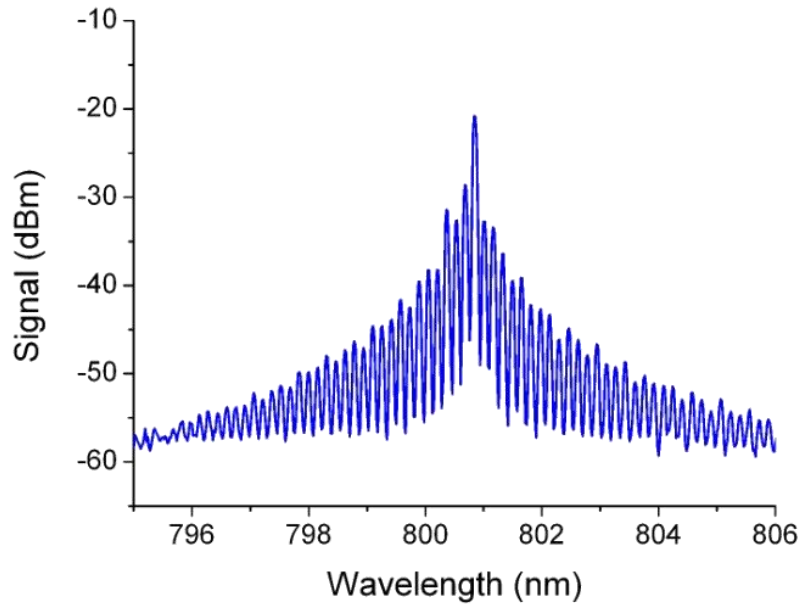
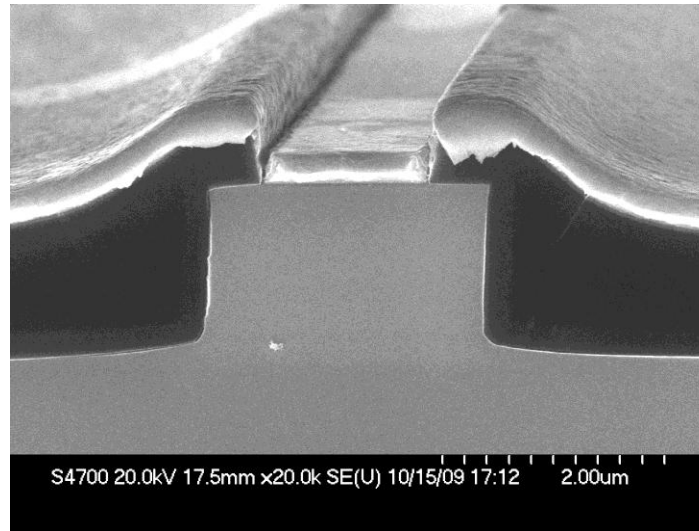



Acknowledgements



University of Glasgow

ICFO^R
Institut de Ciències Fotòniques



EPSRC



Ontario Centres of Excellence
Where Next Happens





All-Optical Wavelength Conversion on a Microchip

sean.wagner@utoronto.ca

photonics.light.utoronto.ca/~wagner



UNIVERSITY OF
TORONTO

