

IBM Software Group

WebSphere. software



# Business Process Management & SOA

Dale Sue Ping  
IBM Software Group

Soudabeh Javadi  
IBM Software Group



© 2005 IBM Corporation

# Agenda

- **SOA & BPM Introduction**
- **Model**
- **Assemble & Deploy**
- **Manage**

# What is Business Process Management?

BPM is a *discipline* combining software capabilities and business expertise through people, systems, and information to accelerate time between process improvements, facilitating business innovation

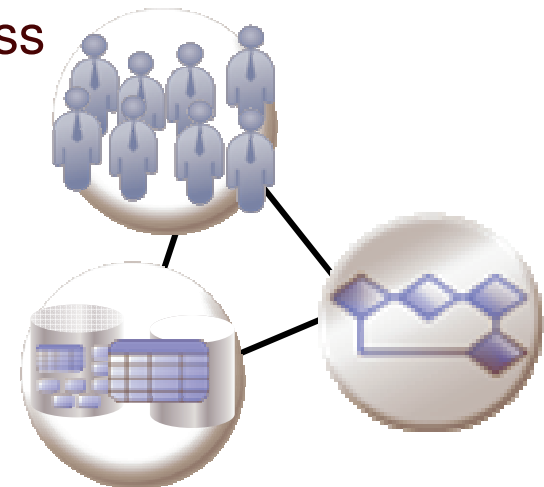

# Services Oriented Architecture & BPM

**SOA allows you**

**To create a set of related and integrated services that support a business process**

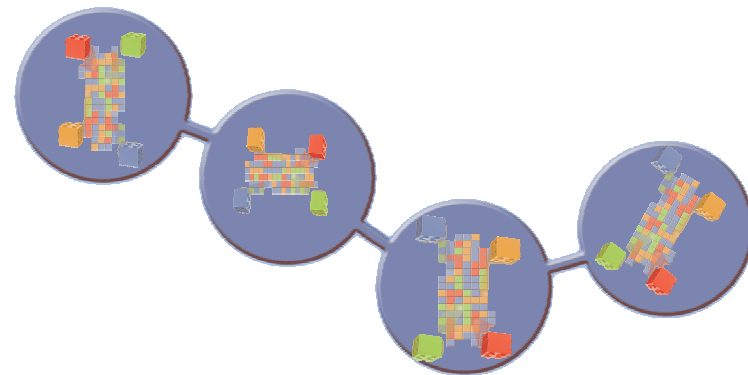
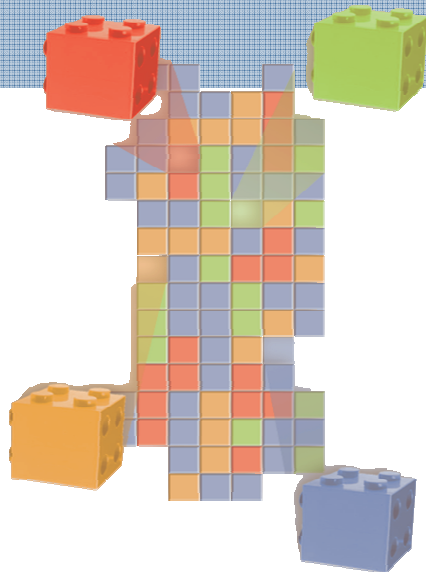

**SOA is at the core of BPM**

**SOA improves how you Design, Manage, and Optimize your business processes by enabling:**

- Reuse of existing assets
- Flexibility in change
- Solution Building Efficiency

# Continuous Business Process Improvement & SOA Lifecycle

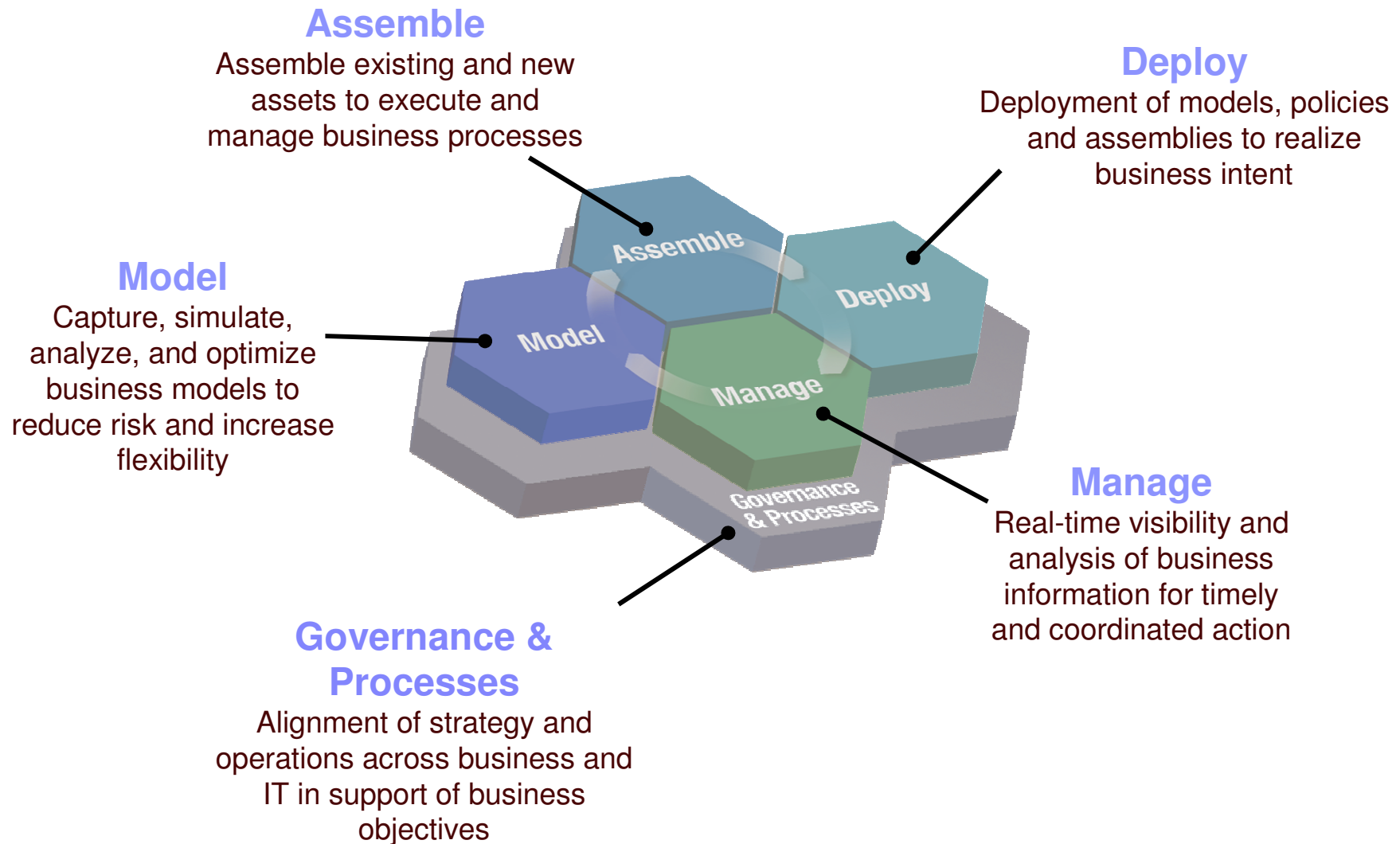

# Managing Business Processes with SOA

## Enabling complete life cycle of business process

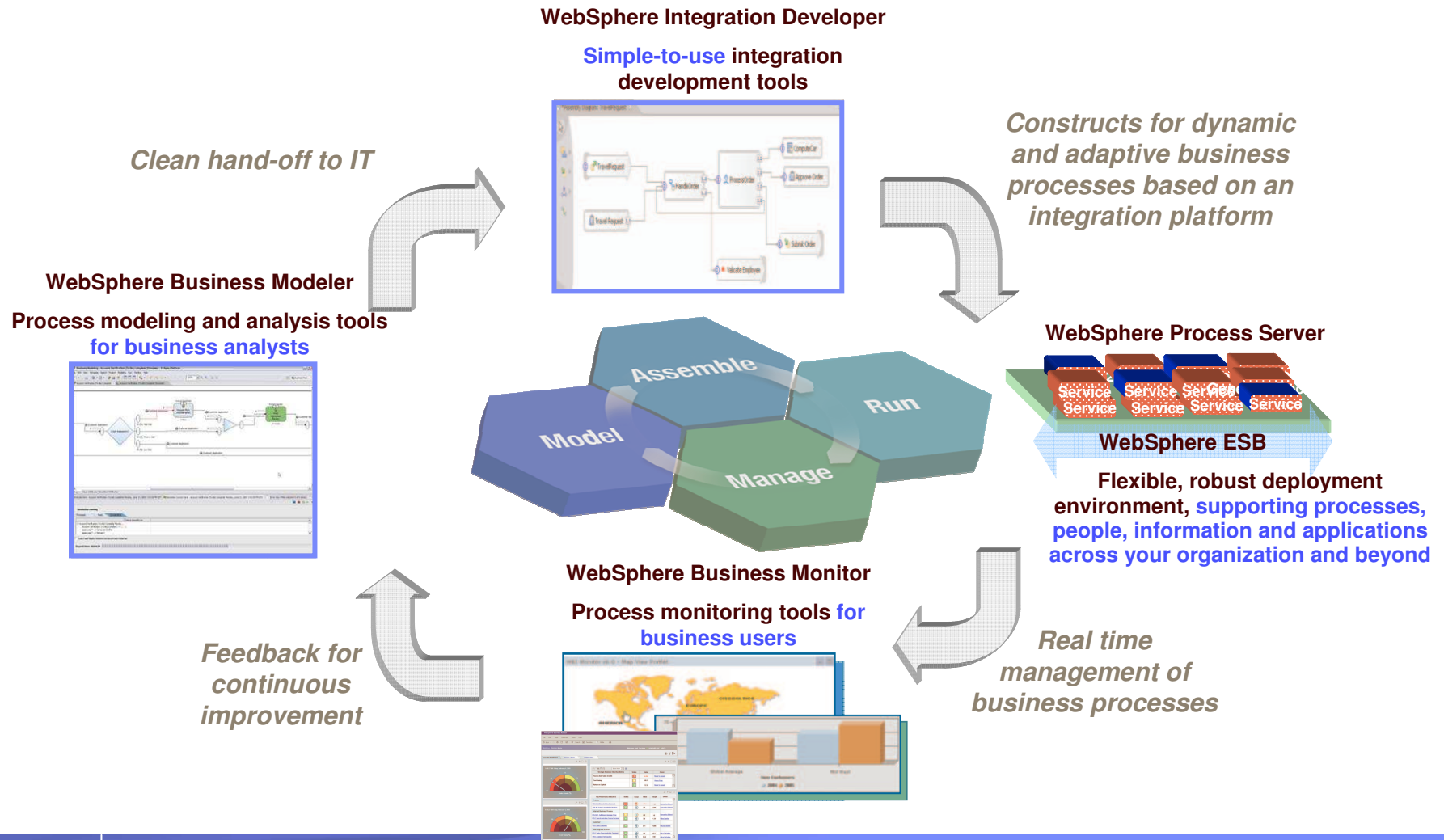

# SOA Reference Architecture

*Comprehensive services in support of your SOA*

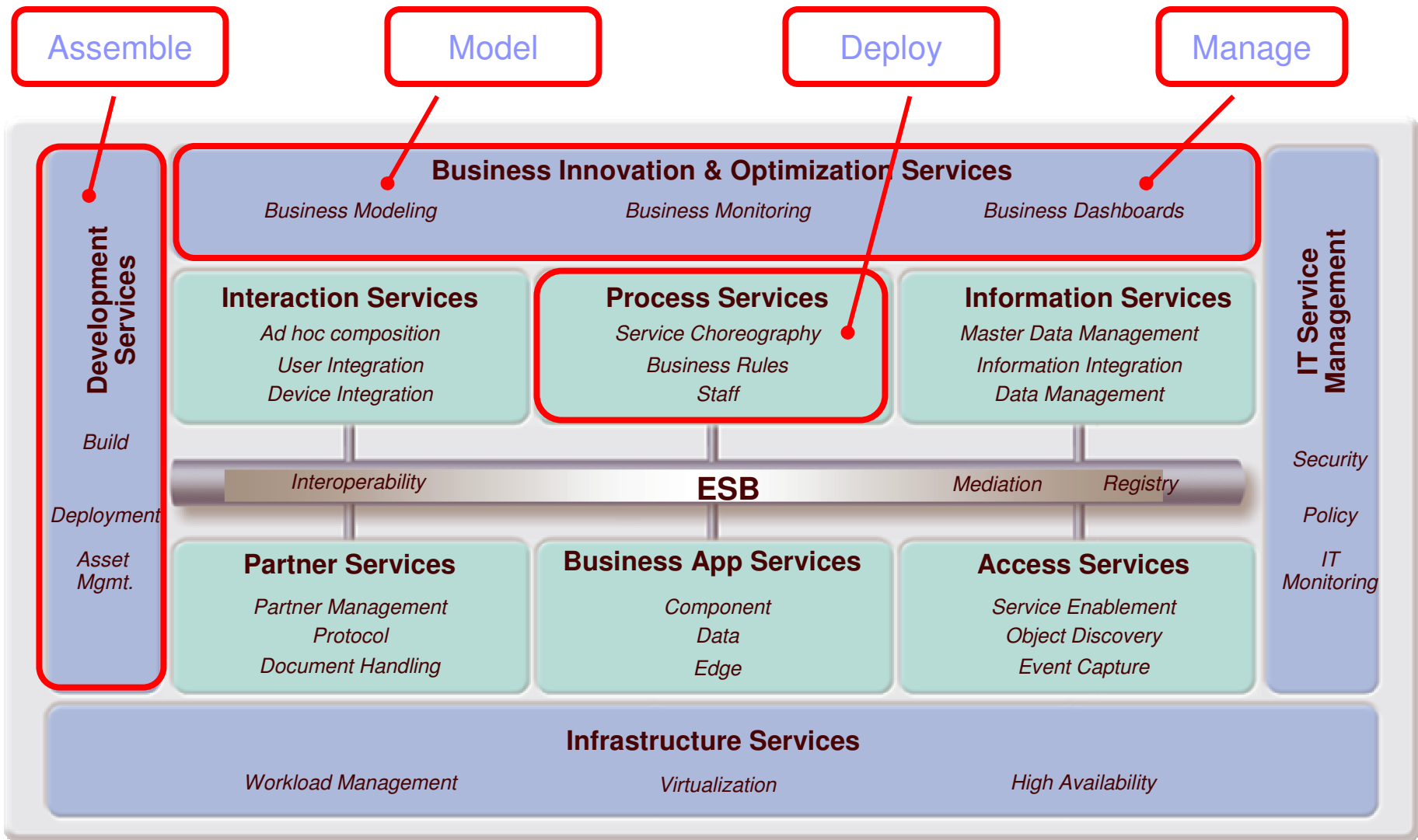

# Agenda

- **Concepts**
- **SOA & BPM Introduction**
- **Model**
- **Assemble & Deploy**
- **Manage**



# Benefits of Business Modeling and Analysis

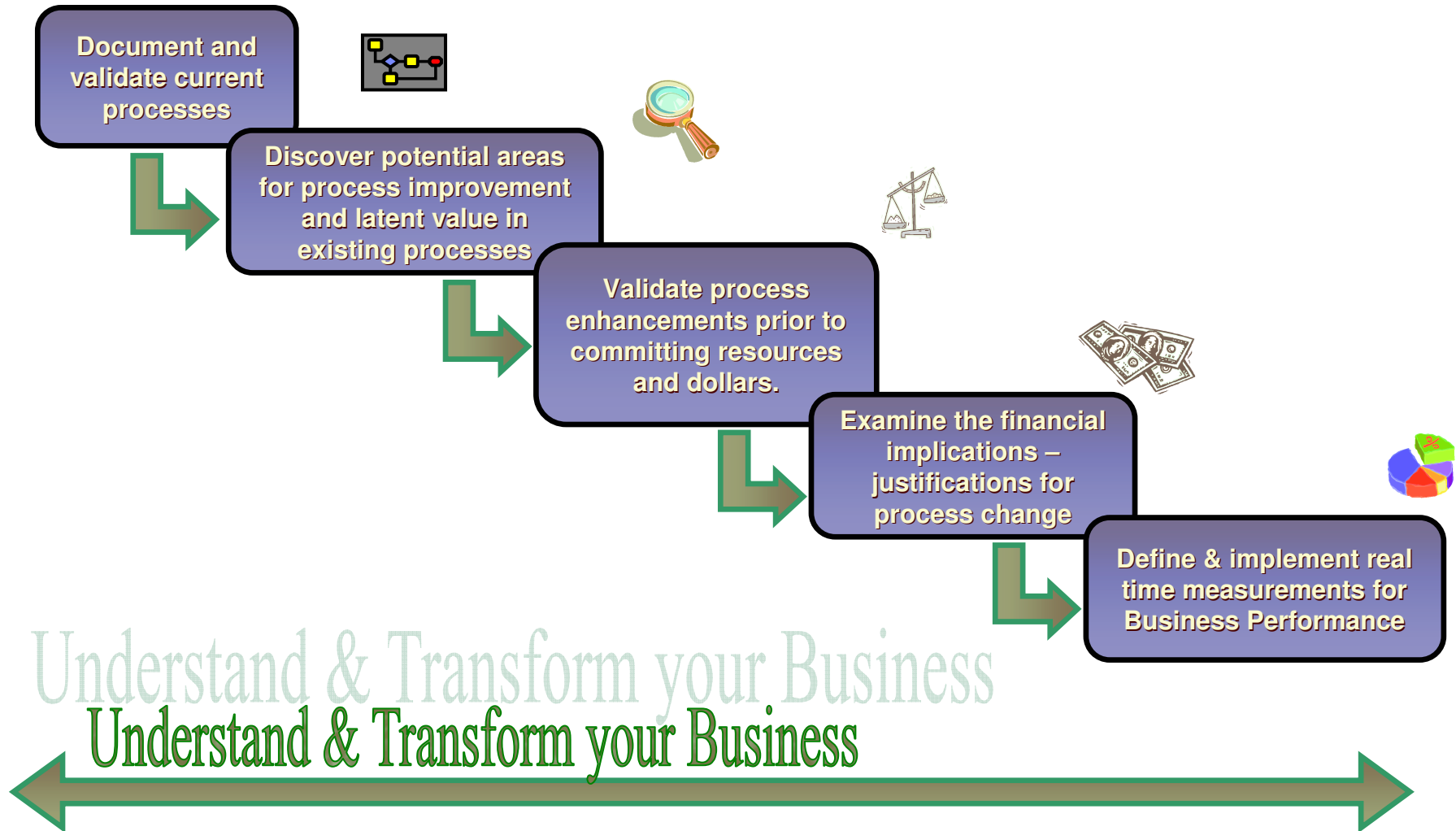

# Business Process Design

## *Drivers for Business Understanding....*

- **Modeling for Compliance/Documentation**
  - **Document processes for use by a business to understand the business process**
  - **Customers use output for training, collaboration, documentation requirements for compliance regulations (Sarbanes-Oxley and Basel II)**
  - **Linkage to real-time monitoring provides a feedback mechanism for reporting requirements needed for compliance**
  
- **Modeling For Redesign**
  - **Document both the current state and future state business process and the comparison to determine Return on Investment (ROI) analysis**
  - **Six Sigma and process improvement are common methodologies**
  
- **Modeling For Execution**
  - **Future state business process has runtime characteristics associated to it, so the model is passed to application, workflow and business process development tools.**

## Bridging the Gap

### Business Modeling

Customers model processes for many purposes:

- Modeling For Compliance/Documentation
- Modeling For Redesign
- Modeling For Execution

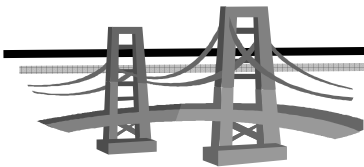

*Domain and Tooling Gap*

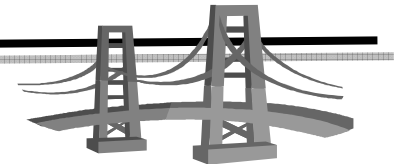

### IT Development

- Application Development
- Service Implementations
- Process Choreography and Human Workflow

# WebSphere Business Modeler

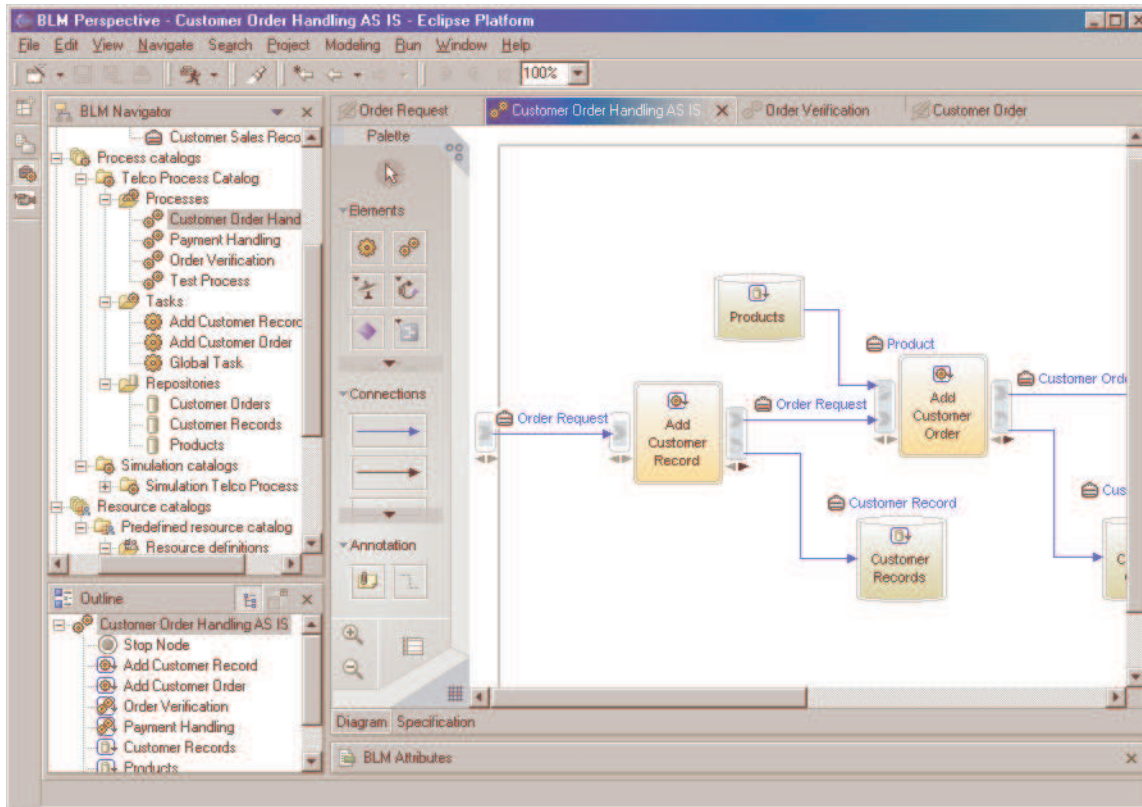

- **Design** business processes quickly and graphically
- **Model** business processes to meet business requirements
- **Simulate** processes to project business benefits
- **Share & Publish** models
- **Integrate** with development tools to deploy

# Agenda

- **SOA & BPM Introduction**
- **Model**
- **Assemble & Deploy**
- **Manage**

# Integration in a SOA World

## *Common Data Model*

- All data is represented consistently
- Standard: **SDO (Service Data Objects)**

## *Common Service Invocation Model*

- All components are represented consistently and invoked identically
- Standard: **SCA (Service Component Architecture)**

## *Common Connectivity*

- Enterprise Service Bus
- Standards: **WS-\*/Web Services standard**

## *Common Service Choreography*

- Components can be choreographed independently of their implementation
- Human tasks as services
- Standard: **WS-BPEL (Business Process Execution Language)**

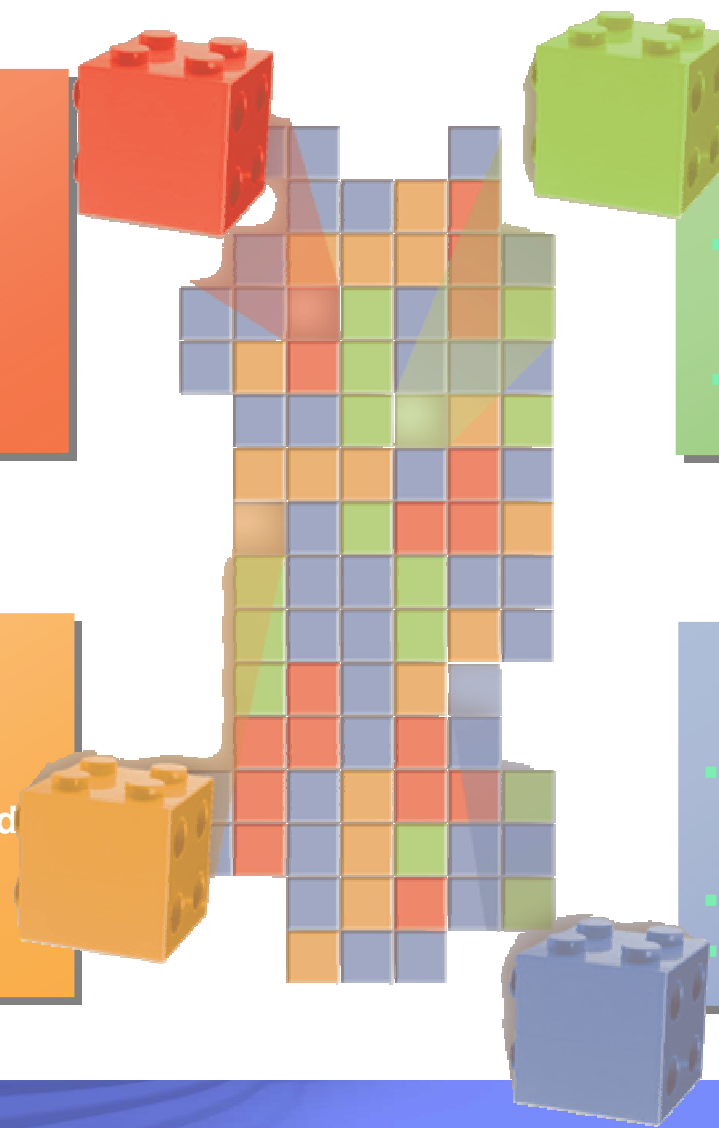

# WebSphere Process Server v6 - Highlights

- 
- **Based on WebSphere Application Server**
    - ✓ Reduces operational risk (clustering, failover, scalability, security)
    - ✓ Reduces operational costs (common administration/support)
  - **Service Oriented Architecture platform**
    - ✓ A uniform invocation programming model (SCA)
    - ✓ A uniform data representation model (Business Objects)
  - **Powerful Staff Components**
    - ✓ Manual task support, ad-hoc human workflow
    - ✓ Multi-level escalation, Prioritization
    - ✓ Multi-client support out-of-box, Client generation framework
  - **Business Processes**
    - ✓ WS-BPEL standard
  - **Business State Machines, Business Rules & Selectors**
    - ✓ Advanced services to build dynamic integration solutions
  - **A single Process Integration platform**
    - ✓ Powerful value-add cross-product integration scenarios
    - ✓ WebSphere Enterprise Service Bus included
    - ✓ WebSphere Adapters included\*
    - ✓ Multi-platform coverage, MQ Integration

# WebSphere Process Server v6 - Components

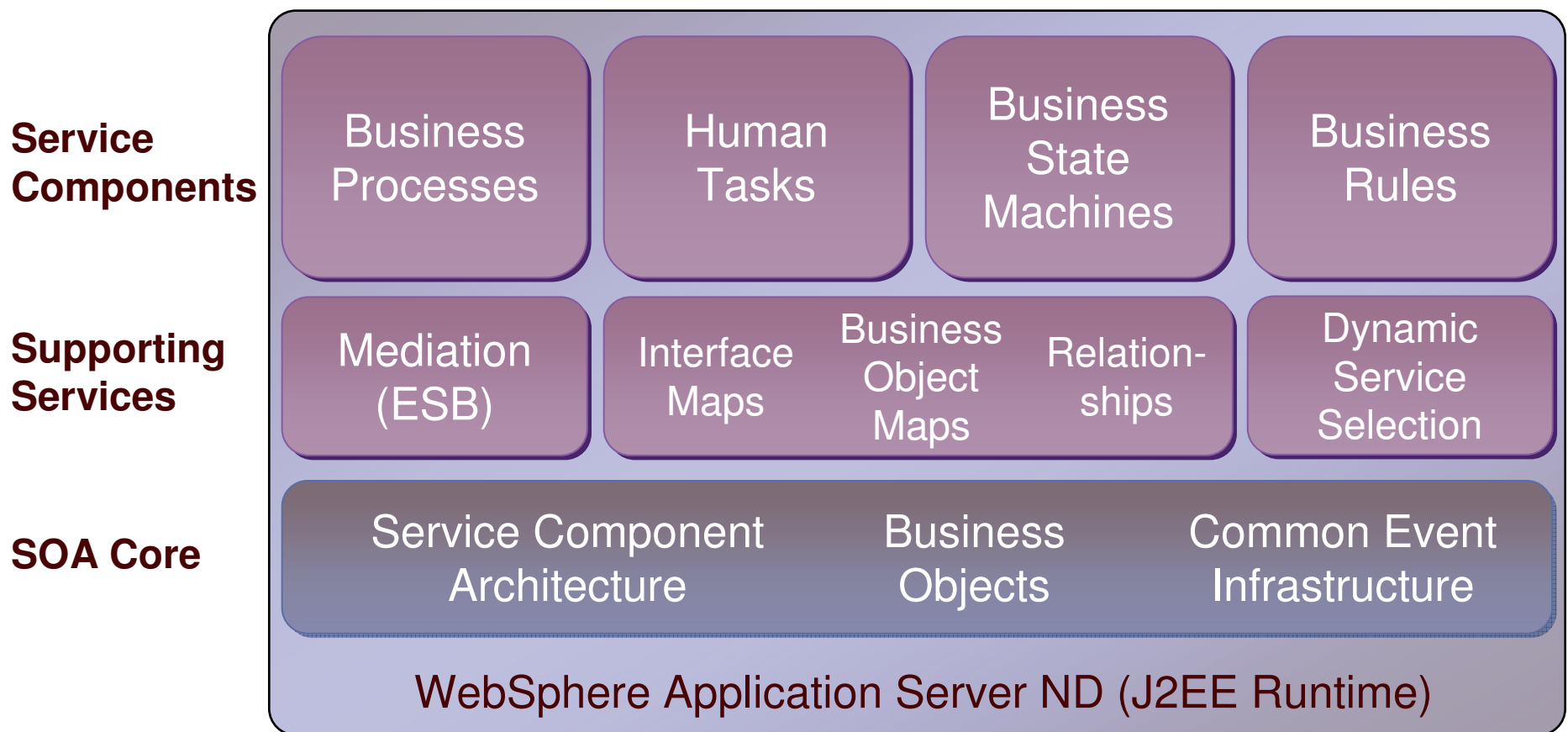



# WebSphere Process Server v6 - Components

WebSphere Application Server ND (J2EE Runtime)

# WebSphere Application Server, ESB & Process Server

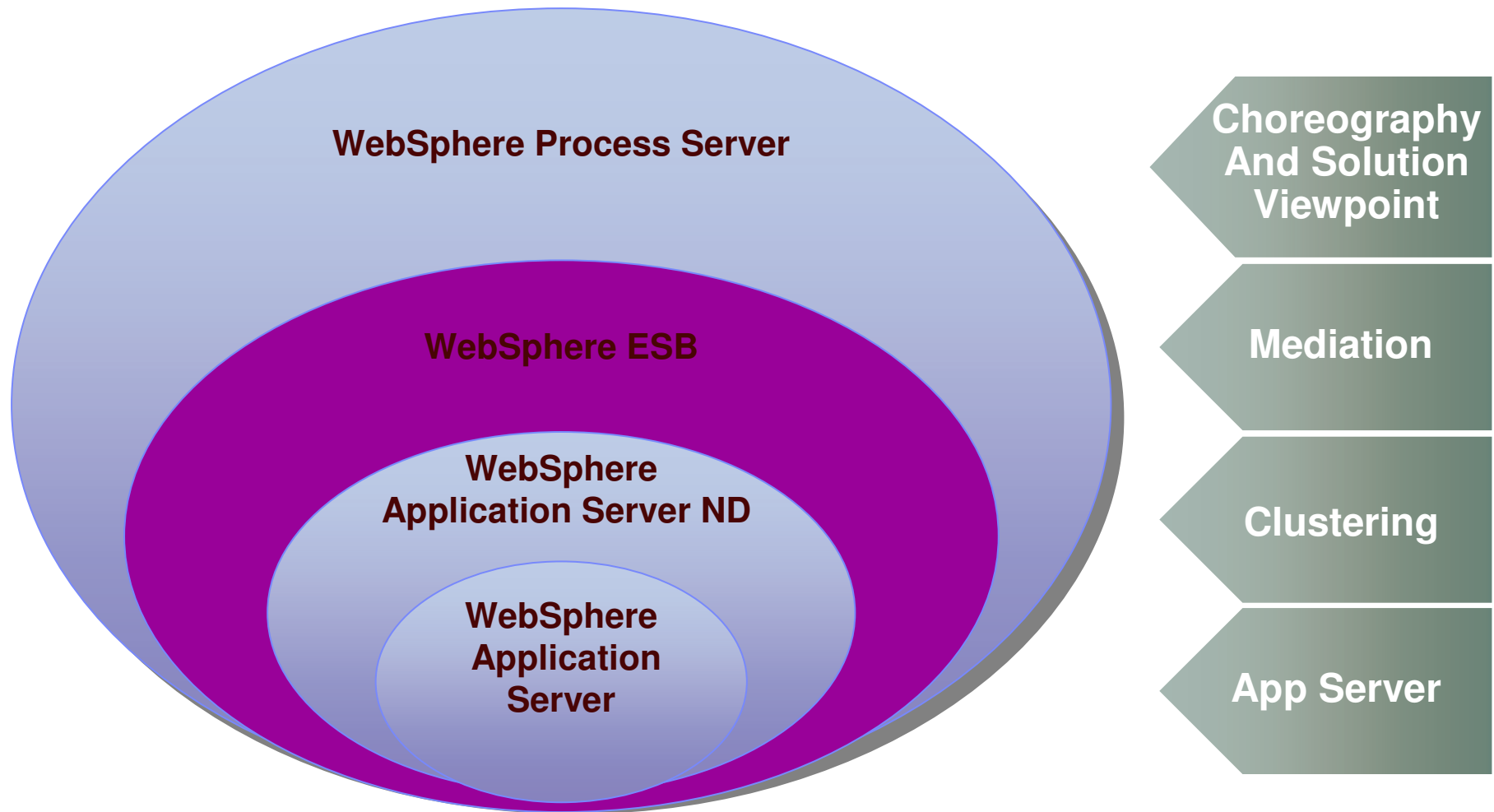

# WebSphere Process Server v6 - Components

**SOA Core**

**Service Component  
Architecture**

Business  
Objects

Common Event  
Infrastructure

WebSphere Application Server ND (J2EE Runtime)

## Service Component Architecture - Description

- **SCA is a service oriented component model for defining and invoking business services that publish or operate on business data**
- **SCA provides a single abstraction for service types that may already be expressed as**
  - Session beans
  - Web Services
  - Java class
  - BPEL
  - Etc
- **Separates “business logic” from “infrastructure logic”**

## Service Component Architecture - Features

- **Provides the Service Component Definition Language (SCDL) for defining service components**
- **Provides the ability to:**
  - Define service components
  - Make services available to clients outside current module
  - Import and reference external services in current module
  - Compose services into larger application components
- **Provides a client programming model allowing client access to service components**

# SOA: Common Invocation Model

## *Service Component Architecture*

IBM, along with BEA, Oracle, SAP, IONA, Siebel and Sybase have announced the new specifications for SCA

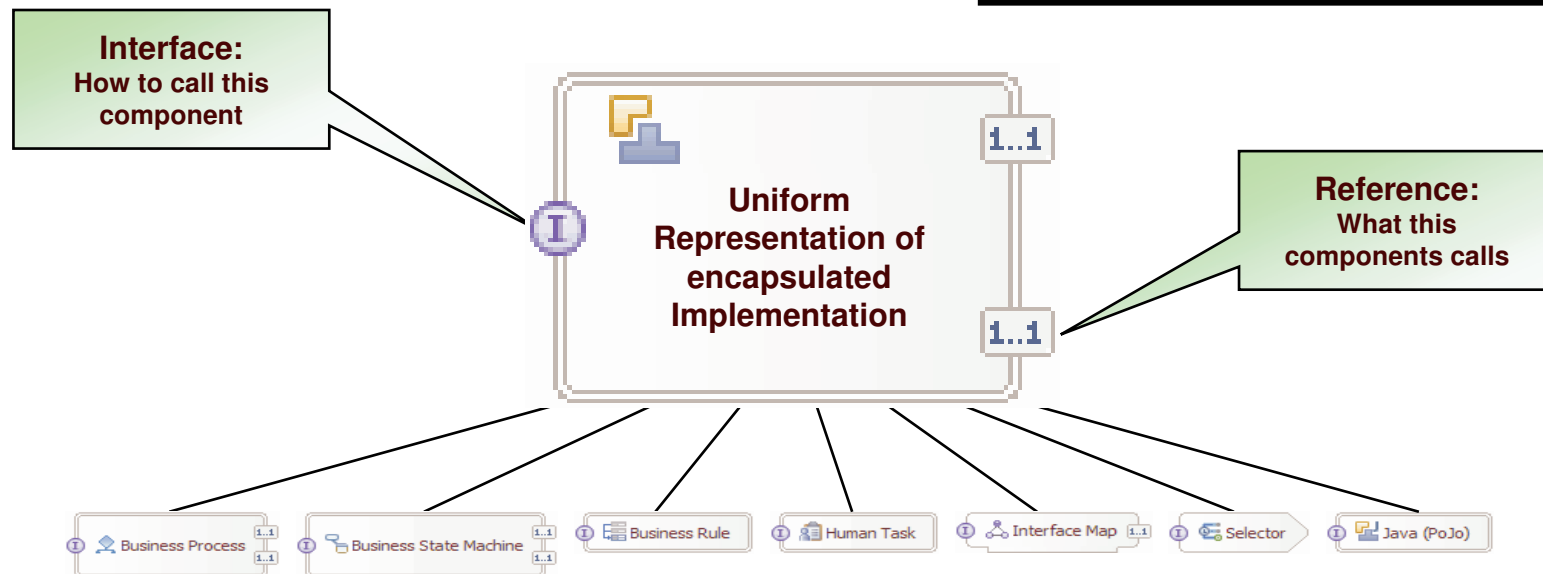

### Business Value

- Encapsulate components for reuse
  - Service Components are wired together to form deployable solutions
  - Business Objects are the data flowing between Service Components
- All components (e.g., services, rules, human interactions) are represented consistently and invoked identically - encapsulation and reuse will reduce development costs
- Increased productivity, reduced cost

# SOA: Common Invocation Model

## *Imports and Exports*

- WebSphere Adapters
  - JCA 1.5
  - WBI “Legacy” Adapters
- Web Services
  - SOAP over HTTP, SOAP over JMS
- JMS (WebSphere Messaging Resources)
  - Point-to-Point and Publish/Subscribe
- MQ
  - MQ native
  - MQ/JMS (MQ-JMS Provider)
- EJB (Session Beans)
- SCA
  - Connect modules to each other without exposing the interface outside of WebSphere Process Server
- Standalone Reference
  - Enables an SCA API Client to call a Module

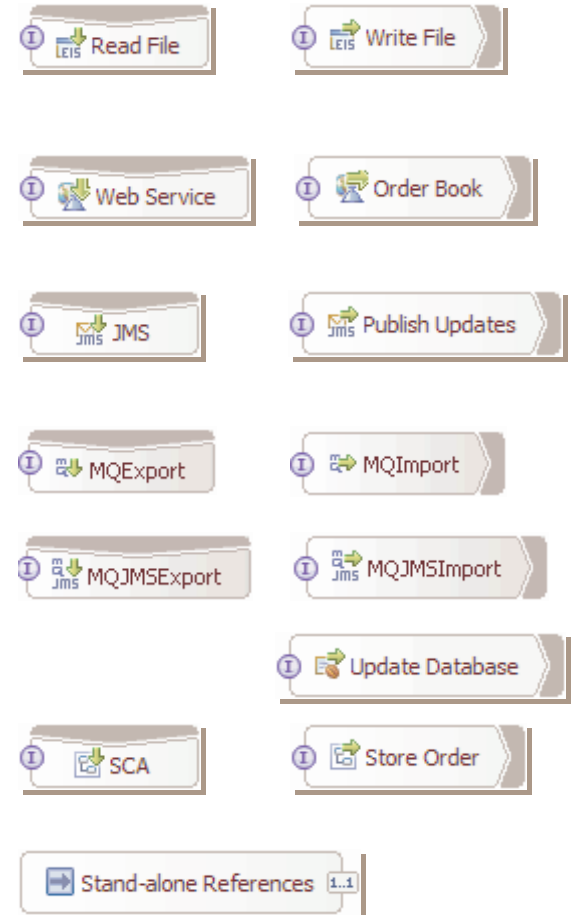

# Assembly Editor

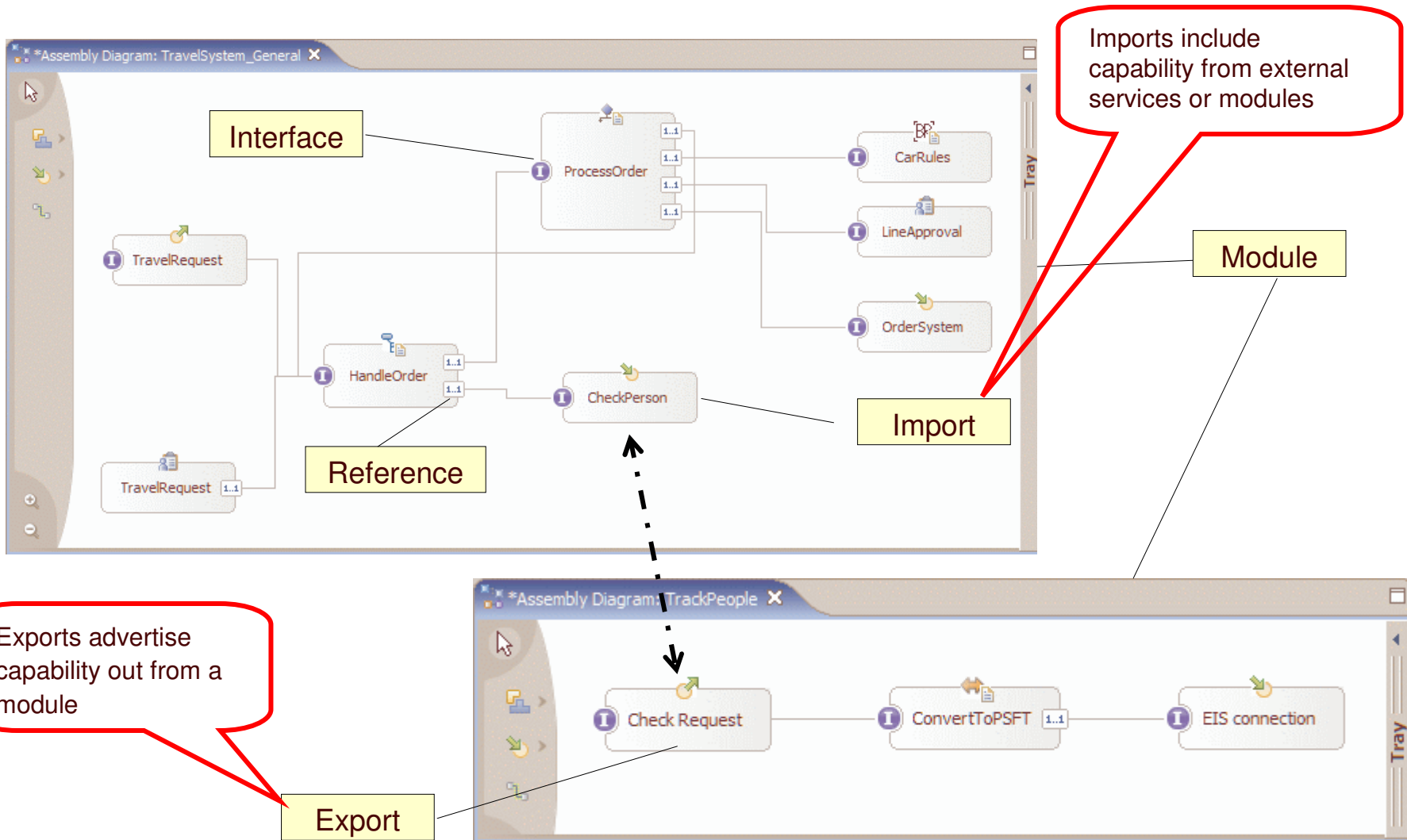



# SCA Invocation Models

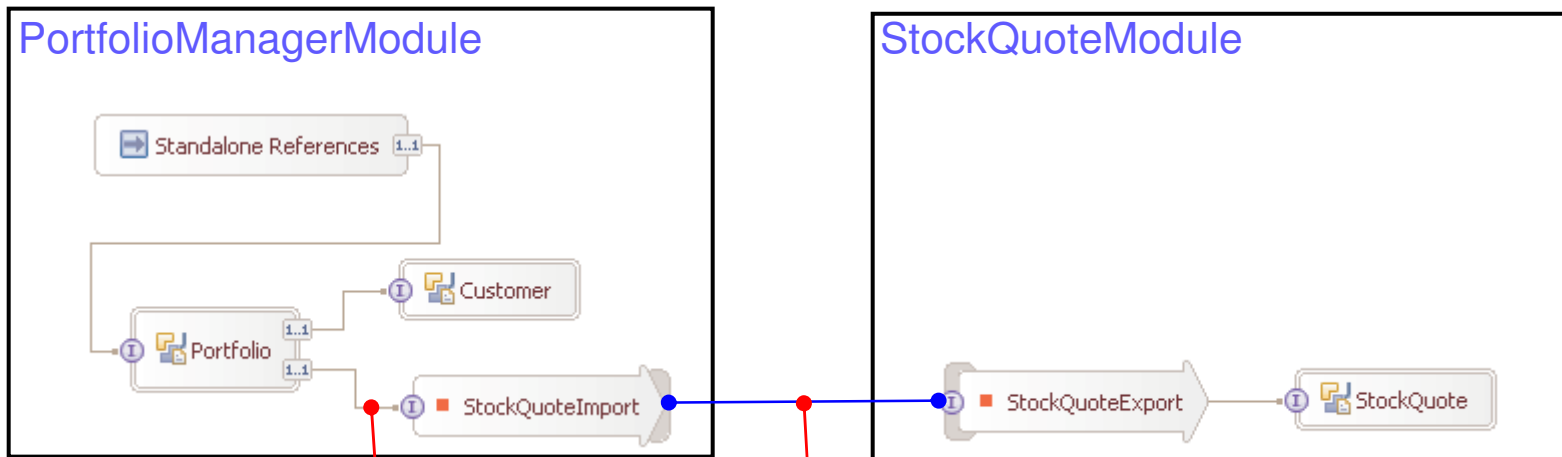

- Invocation Models**
- Synchronous (**by value**)
  - Asynchronous – One Way (by value)
  - Asynchronous – Deferred Response (by value)
  - Asynchronous – Response with Callback (by value)

- Invocation Models**
- Synchronous (**by ref**)
  - Asynchronous – One Way (by value)
  - Asynchronous – Deferred Response (by value)
  - Asynchronous – Response with Callback (by value)

# Using Modules for Building Applications

## *Encapsulation and Reuse Functionality*

### Business Value:

- Module granularity according to business needs
- Leave process logic untouched
- React to change quickly

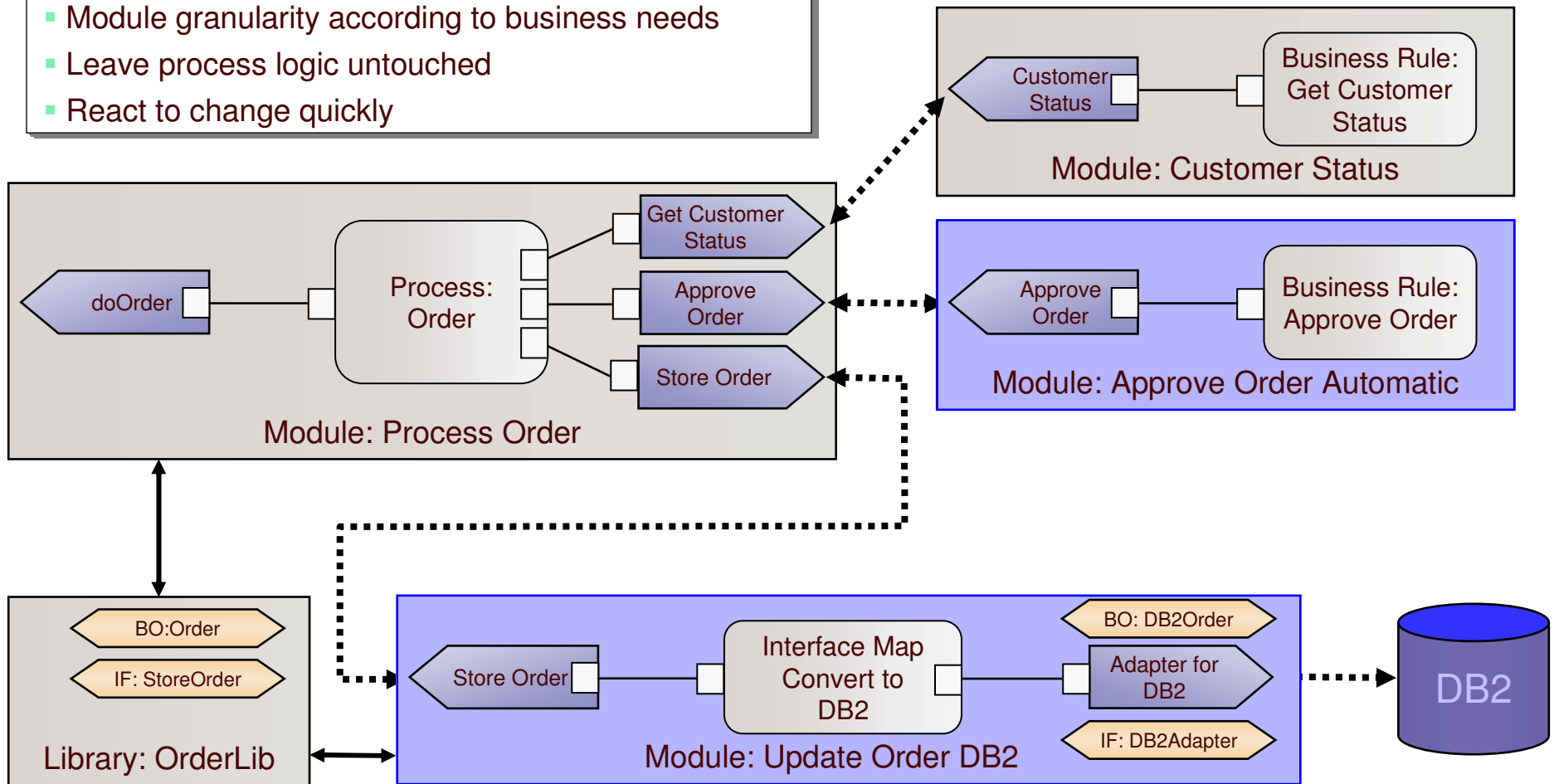

# WebSphere Process Server v6 - Components

**SOA Core**

Service Component  
Architecture

**Business  
Objects**

Common Event  
Infrastructure

WebSphere Application Server ND (J2EE Runtime)

# SOA: Common Data Model

## *Business Objects*

Common data  
representation in  
WebSphere Process  
Server

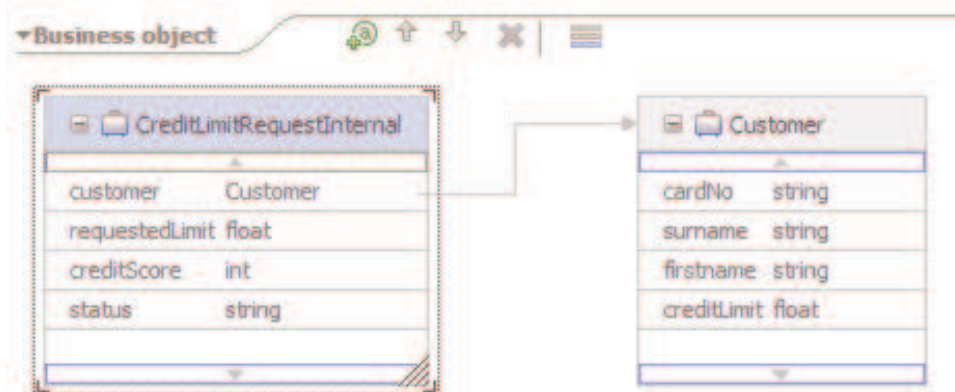

### Supports

- Inheritance
- Aggregation

### Business value:

- Business Objects forms the basis for service orientation by decoupling data definitions from actual implementations
- Common model for representing data within WebSphere Process Server
  - Consistent logical representation, independent of data source or wire format
  - Based upon SDO standard
- Reduces effort, reduces project times, simplifies integration work

# The Common Data Model: Business Objects

- **Business Object Framework consists of:**
  - **Business Object (BO):** Fundamental data structure for representing business data
  - **Business Graph (BG):** Wrapper for a business object or hierarchy of business objects to provide enhanced information such as
    - Change summary
    - Event summary
    - Verb
  - **Business Object Type Metadata:** Metadata provides the ability to annotate business objects with application specific information
  - **Business Object Services:** A set of services provided to facilitate working with business objects.

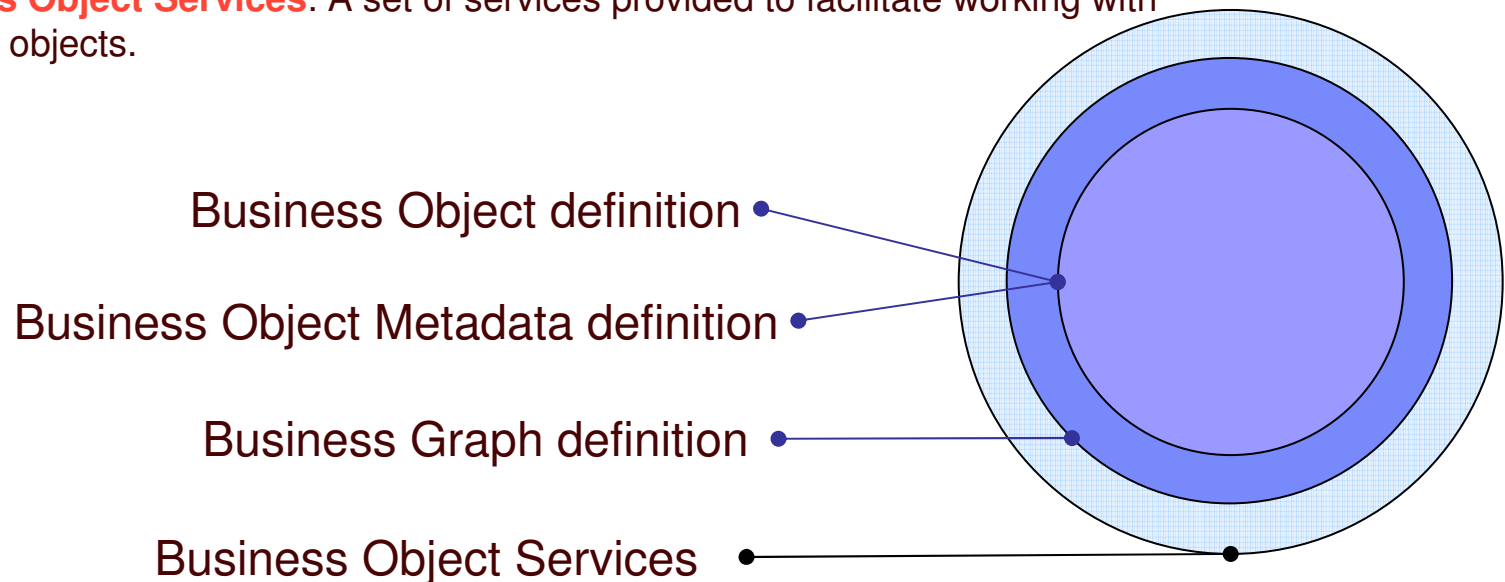

# Business Graph Model Sample

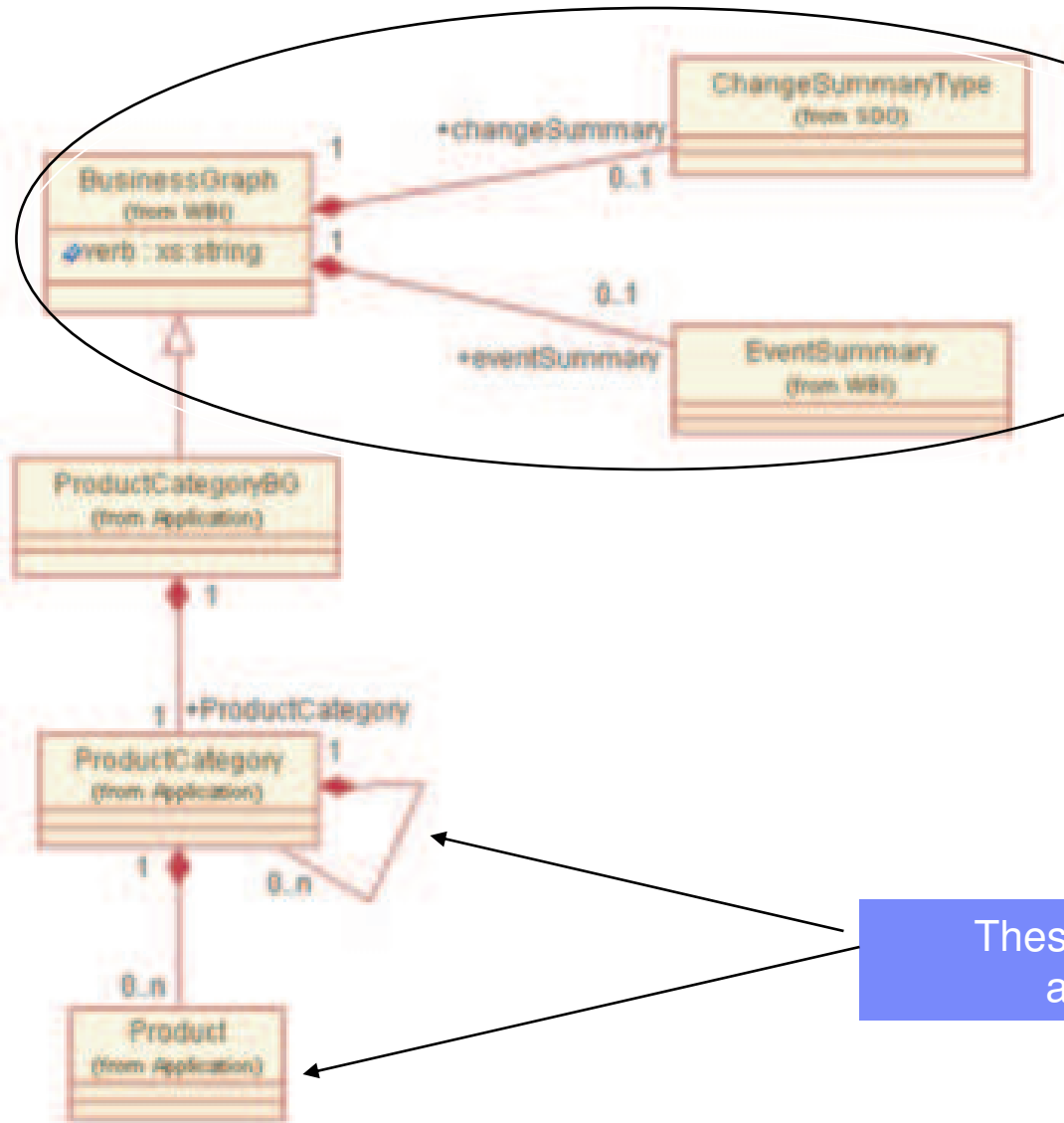

We add this to the picture to carry additional value

These are XSDs that might be 'standard' and we leverage them 'unchanged'

## SCA and Business Objects – Conceptual View

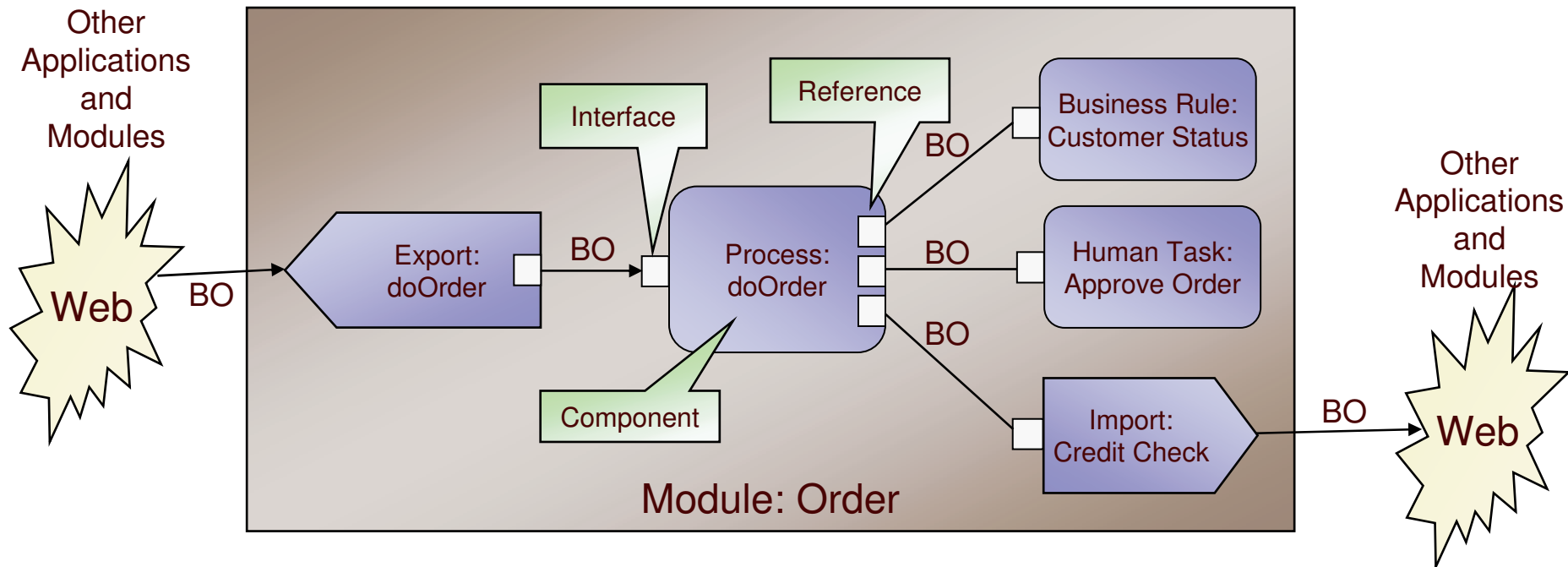

- SCA is the component model
- Components may be wired together
- Business Objects are the data flowing on wires between Components
- Exports advertise capability out from a module
- Imports include capability from external services or modules

## SCA / SDO standardization

- Industry collaboration announced on Nov 30<sup>th</sup>, 2005: A series of specifications aimed at developers building solutions and components using Service Oriented Architecture principles:
  - Service Component Architecture (SCA)
  - Service Data Objects (SDO)
- Open Source SCA runtimes and tools
  - Tuscany project – currently under incubation of Apache to provide a Runtime implementation of Service Component Architecture, which can be used to run SCA applications.
  - Eclipse project aiming to provide tools to enable developers to build solutions using a service oriented architecture, which uses Service Component Architecture as its core model.
- The specs on the IBM web site:
  - <http://www.ibm.com/developerworks/library/specification/ws-sca/>



# WebSphere Process Server v6 - Components

**SOA Core**

Service Component  
Architecture

Business  
Objects

**Common Event  
Infrastructure**

WebSphere Application Server ND (J2EE Runtime)

# Common Event Infrastructure (CEI)

## Recording Business Events

Based on standardized format called Common Base Event (CBE)

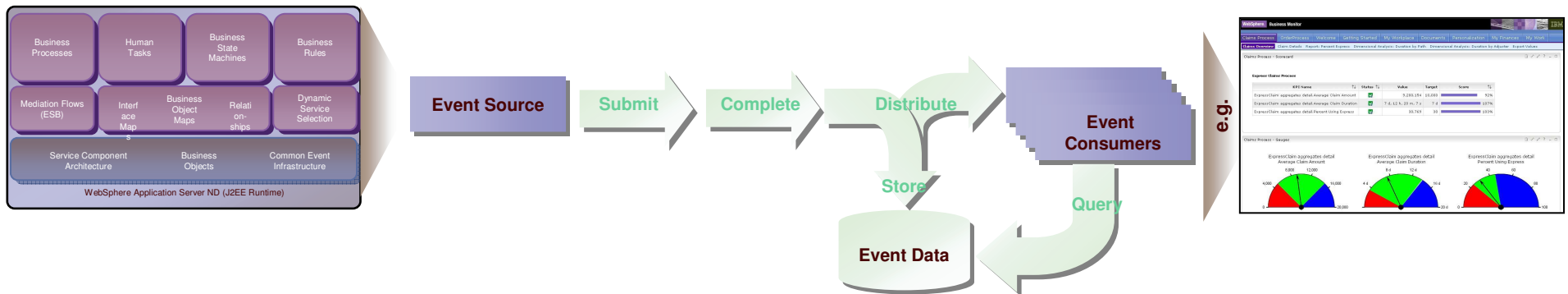

- An *Event* occurs when something significant happens in the system
  - e.g. an application processes a new order, or a failure occurs in a critical part of the system
- All event objects containing the business data are passed to the event infrastructure for
  - e.g. Tracking the progress of a business process, audit trails

### Business value:

- **Common way to publish events from multiple sources end-to-end**
- **Allows other applications or administration tools to easily consume business events**
- **Business Events can be modeled and passed to business dashboards provided by WebSphere Business Monitor**

## Service Components

- **Business Processes**
- **Business State Machine**
- **Human Tasks**
- **Business Rules**

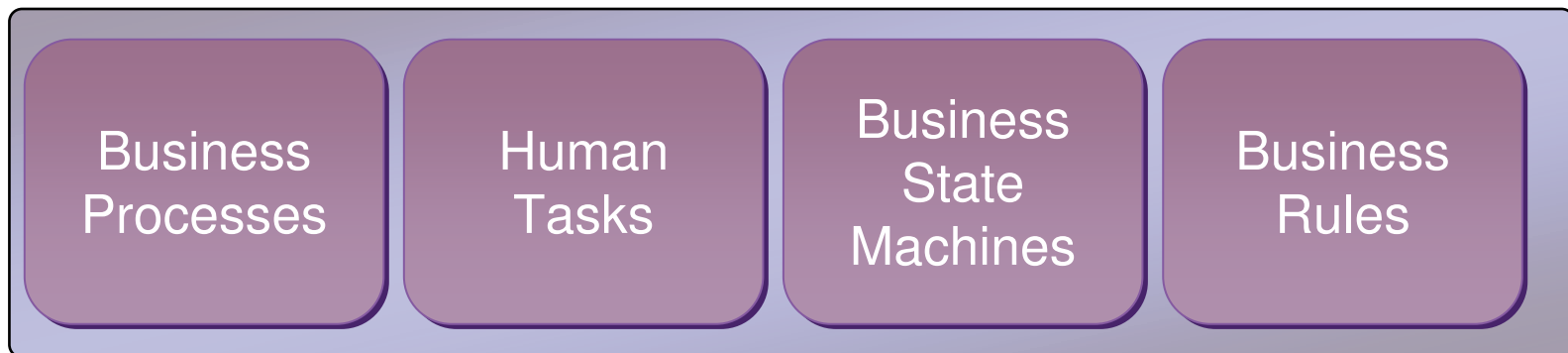

# Two Styles of Service Choreography

Business Processes

- **Business Processes**

- Traditional Business Processes
- Full support for WS-BPEL
- Import from WebSphere Business Modeler



- **Business State Machines**

- Event-driven Business Processes
- Full support for State Machine programming model
  - States, Events, Transitions, Actions, Guards, ...
  - State Machine Authoring / Debugging / Logging



# The Construct of a Business Process

## Constructing a dynamic process using WS-BPEL

Choreographed Services



... while service implementation details stay hidden:

- Human tasks
- Business rules
- Relationship management
- Scheduling selectors
- Mediations
- External services

- ✓ Long-running
- ✓ Straight-through
- ✓ Compensation
- ✓ Event handling
- ✓ Fault handling
- ✓ Parallel paths

## What is WS-BPEL?

- Web Services Business Process Execution Language, also called BPEL
- Previously known as BPEL4WS (Business Process Execution Language for Web Services)
- Industry standard for web services choreography
- A language to specify behavior of business processes
  - As Web services
  - Between Web services
- Builds on and extends XML and Web Services specifications

# A view of some Web Services Standards ...

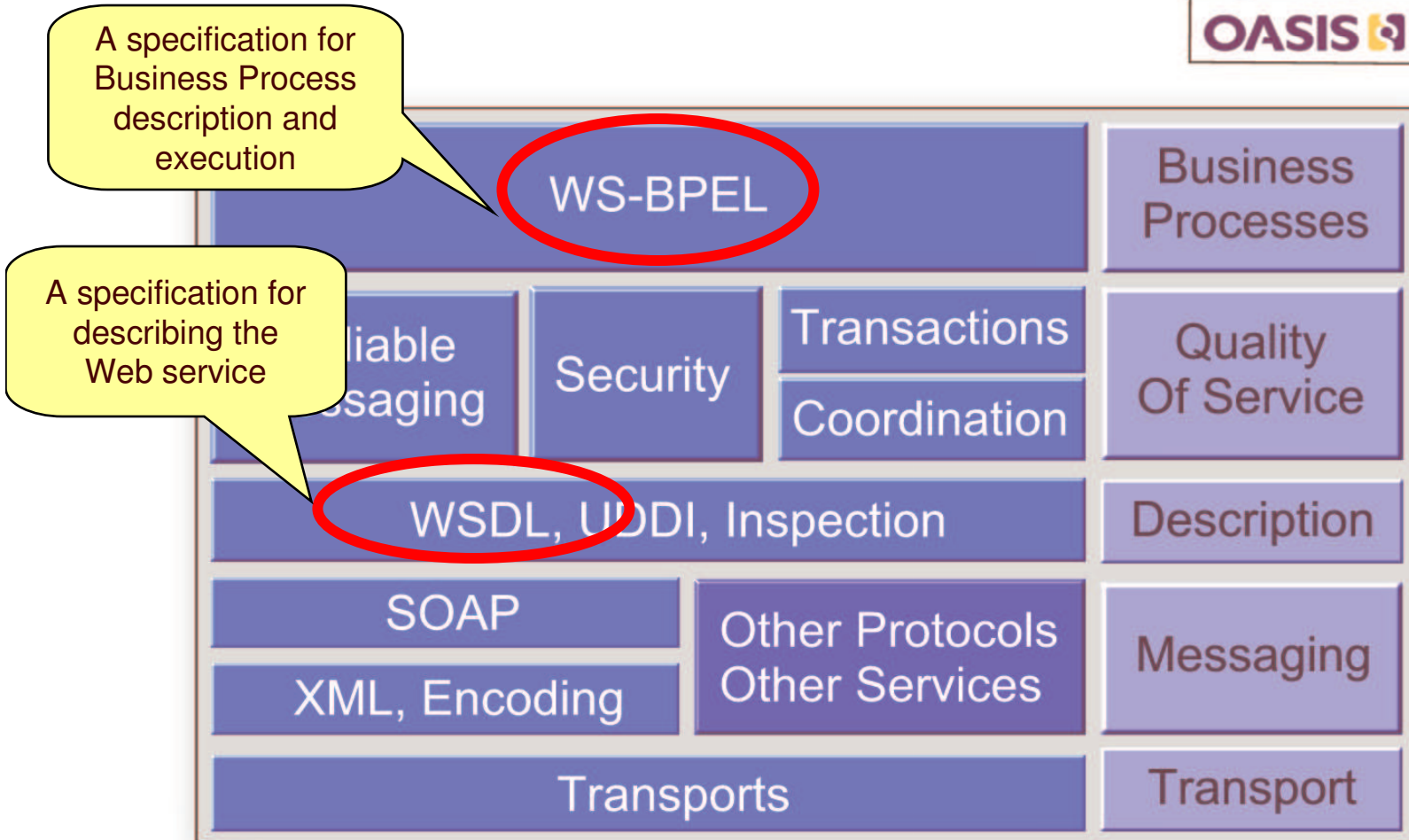

- Web Services Distributed Management (WS-DM) and its Web Event Format (WEF)
- Specification approved on March 9, 2005

## Major Standards Organization

- **W3C (World Wide Web Consortium) – <http://www.w3.org>**
  - Develops interoperable technologies (specifications, guidelines, software, and tools) to lead the Web to its full potential. Covers HTML, HTTP, XML, SOAP, etc. Founded in 1994 and includes 350 member organizations from around the world
- **OASIS (Organization for the Advancement of Structured Information Standards) - <http://www.oasis-open.org>**
  - Drives the development and adoption of Web services, security, ebusiness, public sector and application-specific standards (BPEL, ebXML, UDDI, WSRP, WS-Security, etc.). Founded in 1993, has more than 3,000 participants from 600 organizations in 100 countries
- **WS-I**
  - Is an open industry effort to promote Web Services interoperability across platforms, applications, and programming languages. Provides guidance, recommended practices, and supporting resources for developing interoperable Web services (WS Basic Profile)



# WSDL Usage

- **Service Interface**
  - Port type is a named collection of operations
  - Represents a type of service that can be implemented
  - Elements: types, message, port Type
- **Service Binding**
  - how messages are placed on a given transport at execution time
  - Multiple technologies could be used to access the same service
    - SOAP/HTTP
    - SOAP/JMS
    - RMI
    - Java Calls
    - Adapters
- **Service Implementation**
  - Implementation of one or more service interfaces
  - Contains the endpoint reference
  - Elements: import and service

Three types of WSDL service description documents

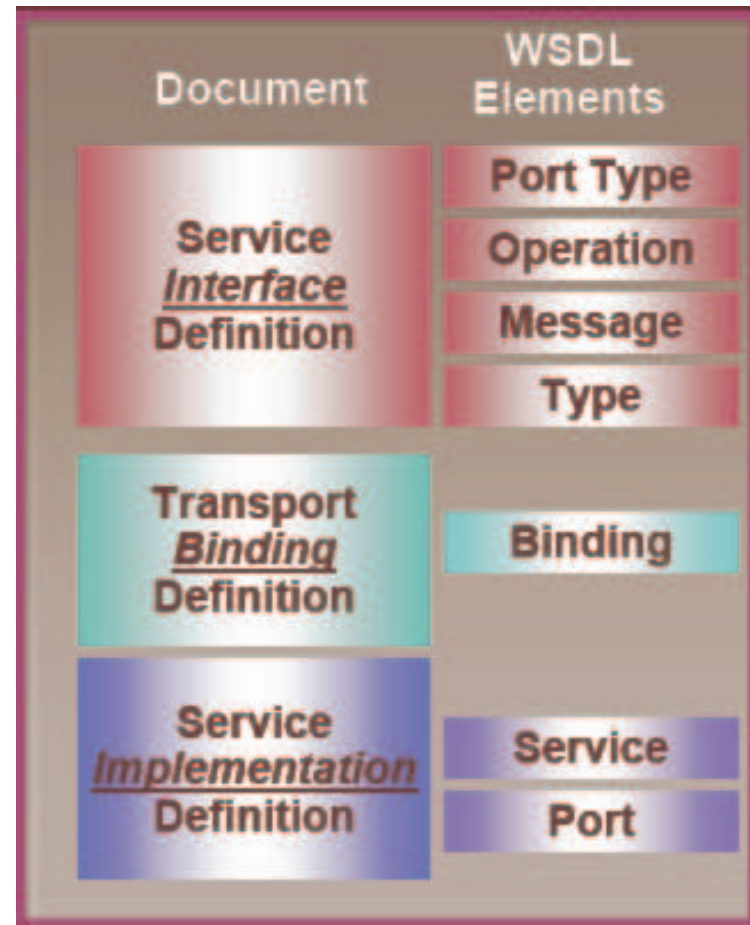

## Elements of a BPEL Process: Activities

### **A BPEL Business Process is composed of**

- **Basic activities**

- Which are the things that we need to do as part of a business process
- Receive input, reply to business partners or other business processes, manage exceptions, make decisions

- **Structuring activities**

- Help us organize and manage the complexity of the flows
- Typical programming constructs

## Elements of a BPEL Process: Variables

- **Hold data that constitutes the state of a process**
  - May be received from or sent to partners
  - Can be specified as input or output variables for invoke, receive, and reply activities
  - May hold state data related to the process and never exchanged with partners

- **Associated with WSDL message types**



## Elements of a BPEL Process: Partner Links

- **Partner: BPEL term for any entity that a process is interacting with**
  - Business Partner, i.e. a web service
  - Internal Service, i.e. an EJB
  - Process Starter, e.g. a web application
  - ...
- **Partner Link: "Placeholder" for a partner**
  - Part of the process definition
  - No need to specify concrete service endpoints within the process model
  - Allows for late binding of partners (at assembly time ↔ build time)
- **Allows for long-running, stateful interactions with a partner**

## Additional basic activities (BPEL extensions)

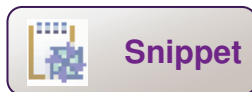

Java snippet



Human task **(also known as “staff” activity in Version 5)**

**Task kind:** inline task

**Task type:** participating

Alternative to “inline task”:

→ Standalone task (NEW)

implemented as BPEL invoke activity

and human task SCA component.



## II4BPEL - Information Service Activity

- **Direct integration of information management services (SQL, ETL, Federation) with BPEL business processes**
- **Access to**
  - Information Server
    - Access via WebSphere Information Server Director
  - Full SQL: Direct access to relational database systems
- **Benefits:**
  - Simplified, faster process development, improved flexibility and performance
  - Out-of-box integration - direct data access w/o java coding
  - powerful cross-product scenarios

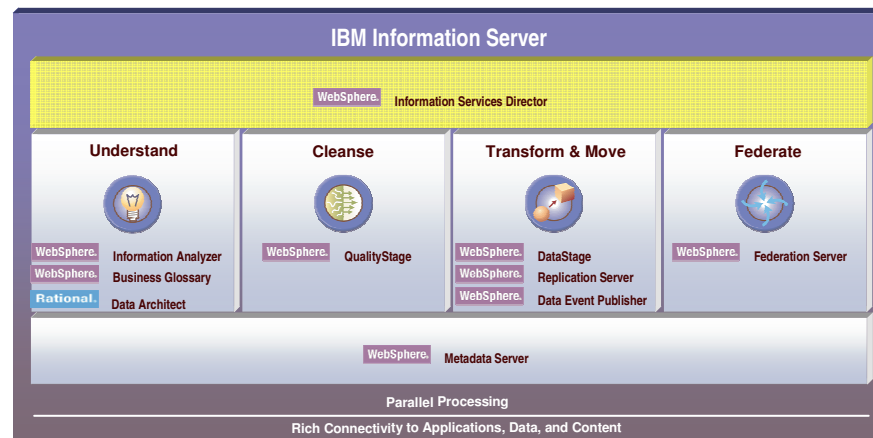

# Information Service Activity

- **Information Service** activity can be part of any BPEL business process.
- **BPEL Variables** hold configuration data (data sources and set references) and is input to Information Service activity
- Direct mapping of input and output parameters to BPEL variables

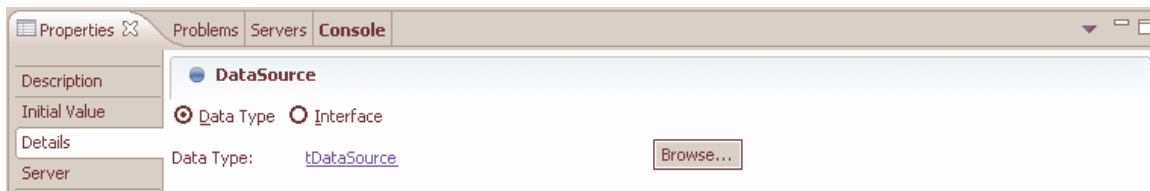

- **Specify details for Information Service activities**



# Scopes and Handlers

## Scope

- Local variables
- Local partner links
- Local correlation sets
- Set of activities (basic or structured)

## Handlers

- **Event handlers**
  - Message events or timer events (deadline or duration)
- **Fault handlers**
  - Dealing with different exceptional situations (internal faults)
- **Compensation handler**
  - Undoing persisted effects of already completed activities
- **Termination handler**
  - Dealing with forced scope termination (external faults)

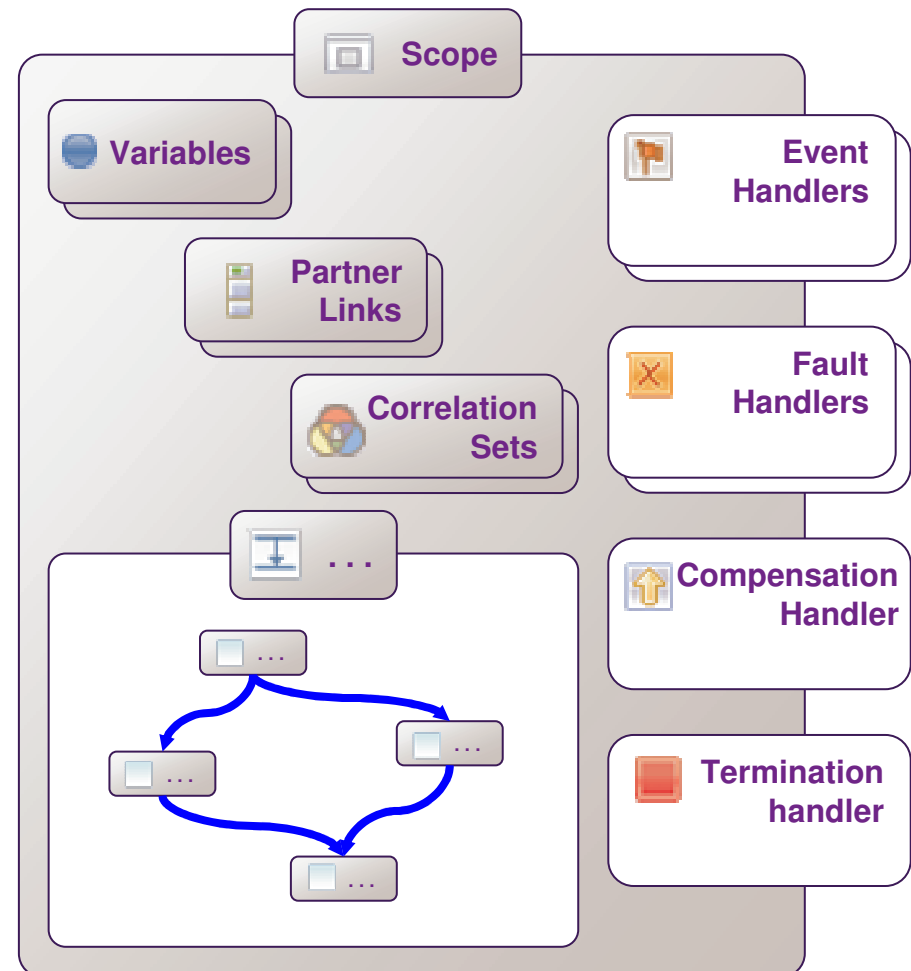



# WS-BPEL 2.0 in WPS V6 - Business Flow Manager

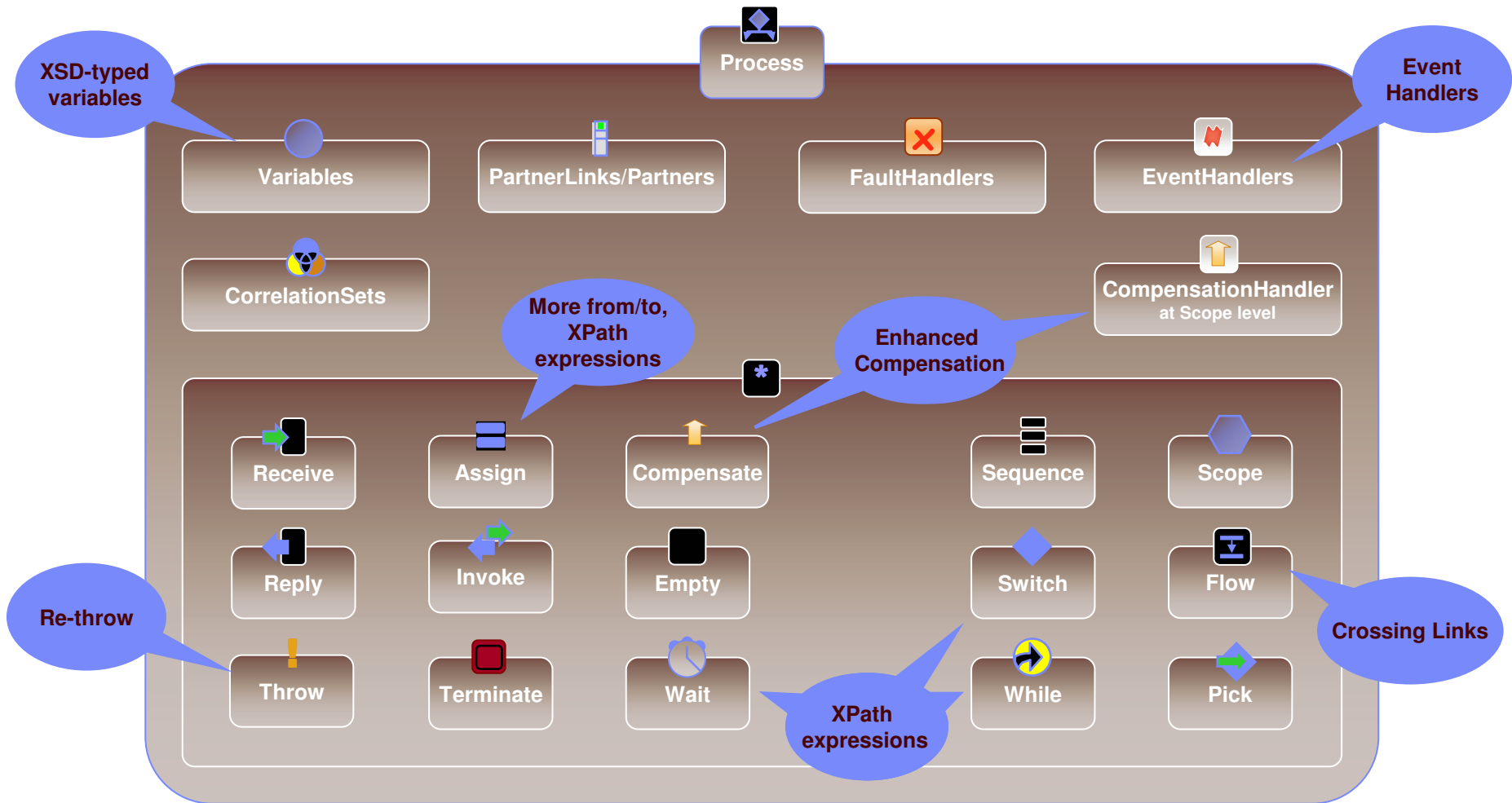

# Human Workflow in BPM

Human  
Tasks

- **Human workflow is about assigning the right work to the right people at the right time, with the information they need, presented for immediate action**
- **Human Workflow is required for important business scenarios**
  - Exception handling for automated process steps
  - Manual review and approvals
  - Legal regulations including human decisions
  - ...and many more
- **Demonstrate Compliance and policy fulfillment**
  - Policies, Rules, Regulations, Legislation
    - Sarbanes-Oxley (financial reporting)
    - HIPAA (reduce paperwork)
    - Basel II (financial risk assessment)
  - Quality Initiatives
    - ISO 9000
    - Lean management
    - etc

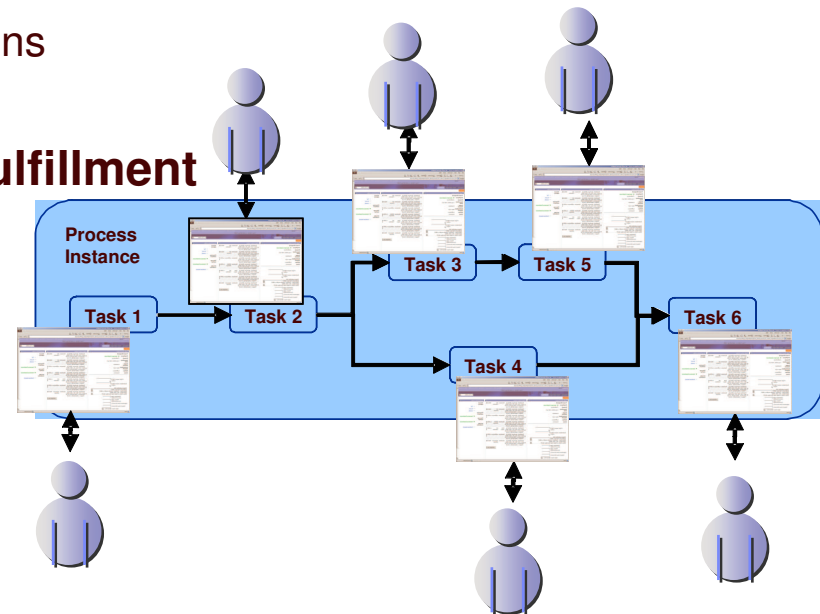

# The Construct of a Human Task

*Accessible capabilities to fine-tune business processes to address business scenarios requiring human intervention*

**Create powerful human-centric processes**

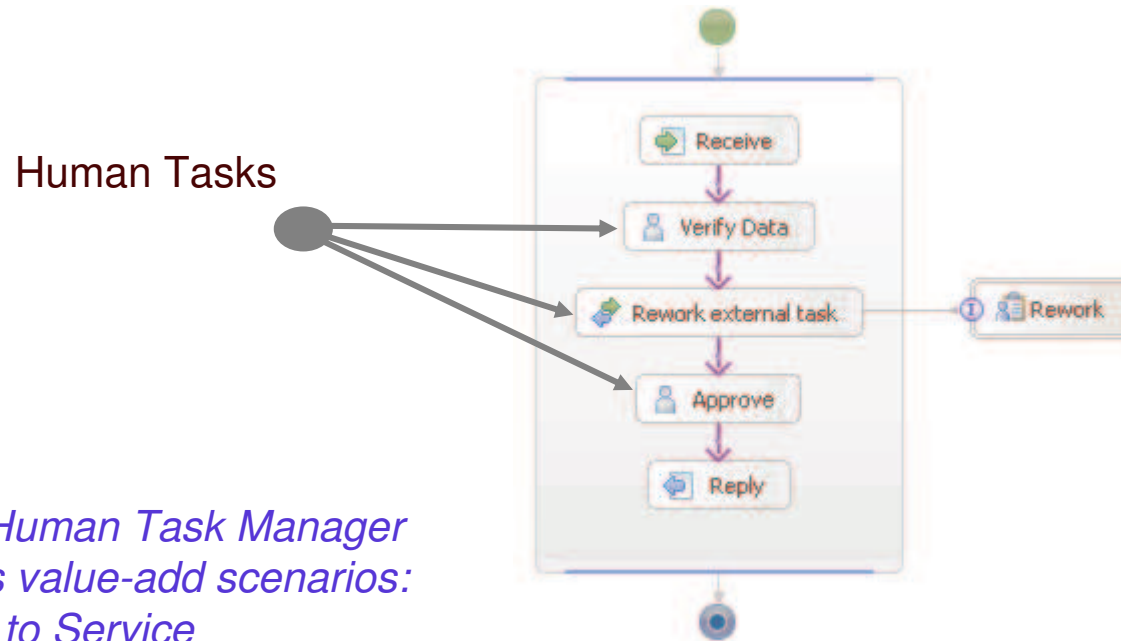

- ✓ **Inline**
- ✓ **Standalone**
- ✓ **Multi-client support**
- ✓ **Escalations**
- ✓ **Authorization**
- ✓ **Ad-hoc**

*... while Human Task Manager handles value-add scenarios:*

- *Human to Service*
- *Service to Human*
- *Human to Human*

# Human Task Manager – Human Tasks

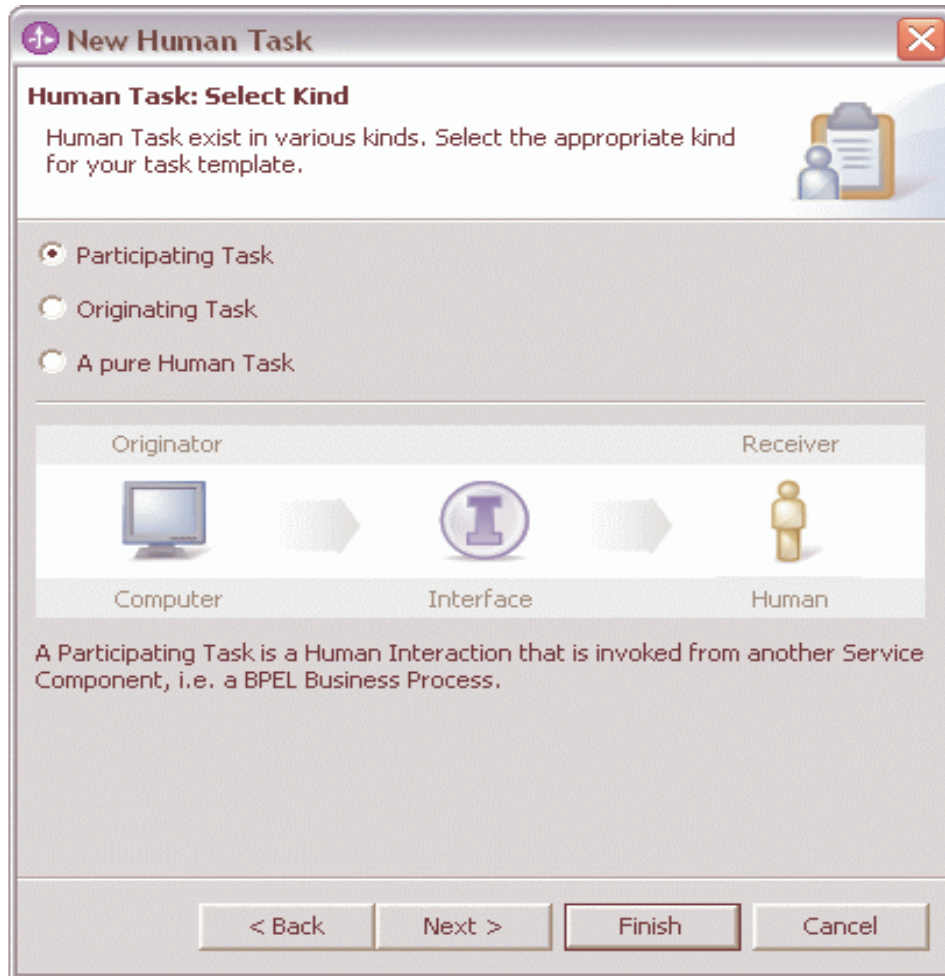

- **A Standalone Component**

- Not restricted to just invocation from WS-BPEL Processes

- **Three kinds of Human Tasks**

- Machine to Human (participating)
  - Invoke humans as a service
  - Component creates a work item for Human interaction (WS-BPEL)



- Human to Machine (originating)
  - Human interfaces to service
  - Human interaction invokes a Component (i.e. Business State Machine)



- Human to Human (pure human task)
  - Ad-hoc usage of To-Do list
  - Human interaction invokes a Component which creates a work item for another Human



- **Human Task Components**

- Implement WSDL interfaces
- Are implemented as SCA Components
- Fit the overall SOA Model

# Ad-Hoc support in WebSphere Process Server

*Allowing for dynamic changes in human workflow scenarios*

## Ad-hoc

- **Create sub-tasks**

- Ownership stays at original task
- Subtasks contribute to completion of parent task

- **Create follow-on tasks**

- Ownership is passed to follow-on task
- Follow-on task is responsible of completion

- **Follow-up on human tasks**

- "Remind me later" for completion of already started task
- "Suspend until"

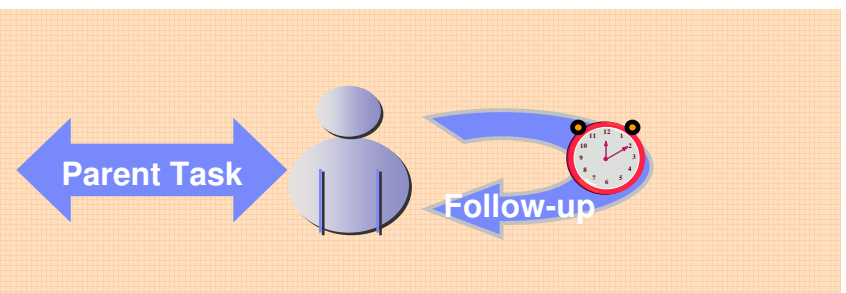
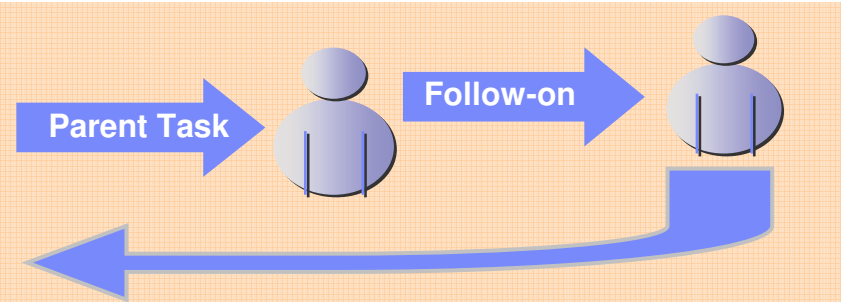
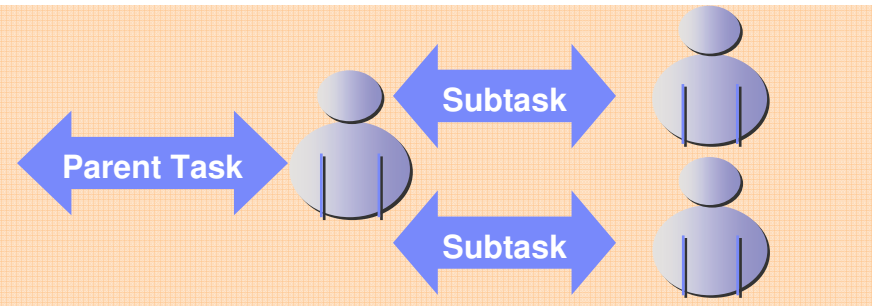

# Escalation and Notification

- **Used to handle overdue tasks**
  - Create notifications if a task's progress is behind the expectations
  - Send notification based on time and task state
  
- **Possible ways to send notifications:**
  - *work items* for a set of users
  - *e-mail* notification
  - sending a notification *event* to a registered consumer (via callback)
  
- **Escalation structure**
  - One or many escalations per task
  - Single or chained

# Client Generation for Human Workflows

- **Out-of-box custom client generation for human workflows**

- Generation of JSP-based client application based on process
- Worklist support, type validation

- **Benefits:**

- Click & Use for immediate results
- Focus: Business user
- Possible starting point for customers to add more features or create own client

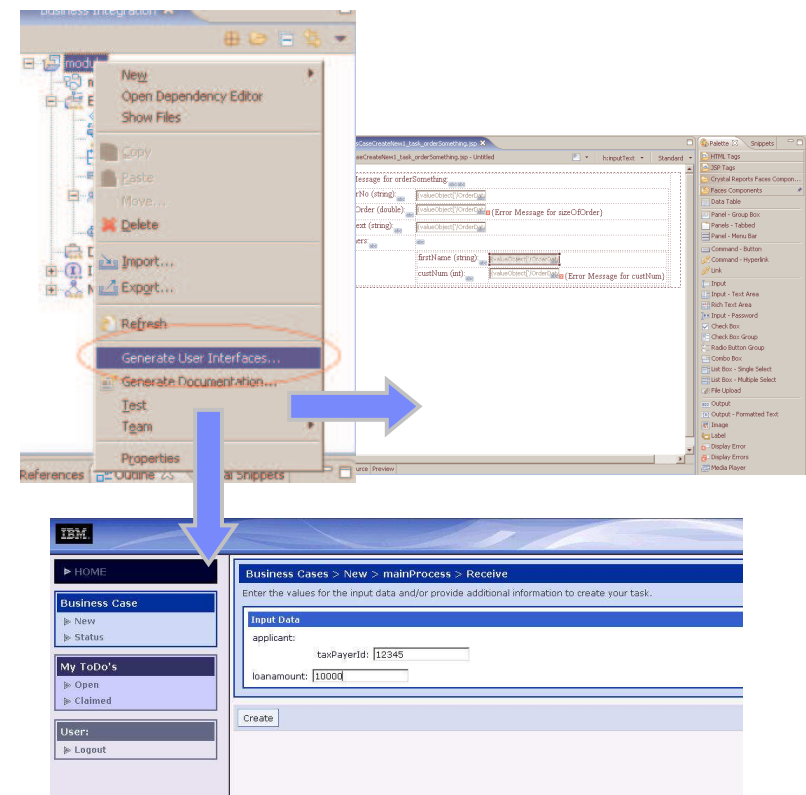

# Business State Machines

A 'Business State Machine' is an implementation of a business model that 'executes'; moving from one state to another state based on real-time events.

- State Machine Implementation
  - Based on UML 2.0 State Machine Models
  - Event driven business processes
  - Creates WS-BPEL under the covers
- Simple/Complex States
  - Entry/Exit
- Transitions
  - Events
  - Actions (invokes)
  - Guards (condition)
  - Timeout

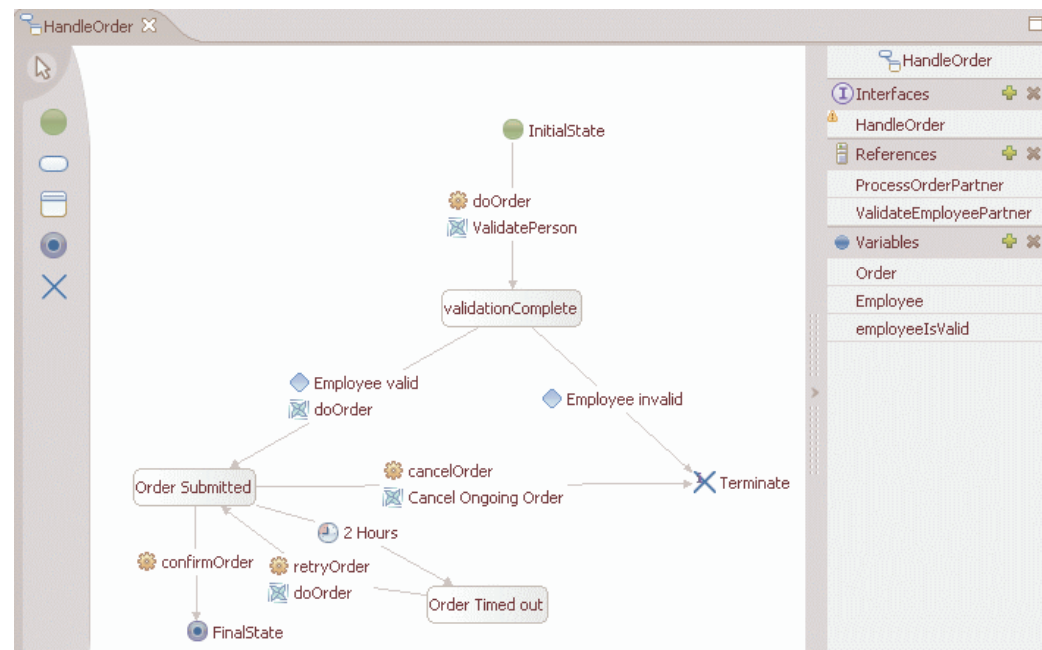



## When to use a Business State Machine

- **Use a Business State Machine when:**
  - the business process is heavily event-driven
  - the reaction to these events is dependent on the process state
  - the process may revert to prior states
  - some sequential steps ok
  
- **Use a BPEL process when:**
  - steps in a process tend to happen in sequence
  - some event handling and looping is ok

# Business Rules



Business  
Rules

- **Externalize Business Logic from an application (business process)**
  - Easy change of logic that may change
- **Dynamically Update Rules in Runtime on the fly through Web Interface**
  - NLS enabled free text representation for rules
- **Most-requested Business Rule Functionality**
  - Decision Tables
  - Rule Sets (If/Then Rules)
  - Rule Templates
  - Action Rules
- **Ease of Use**
  - Rule Group: detailed implementation encapsulated in a component with a well defined interface

# Business Rules

*Externalize Business Logic for business flexibility*

## ■ Rule Group

The screenshot shows the configuration for a Rule Group. It includes sections for 'Active Destinations' and 'Available Destinations'. The 'Active Destinations' section has a 'Default Destination' set to 'getDailyRateNormal' and a table of active destinations with columns for Start Date, End Date, and Destination. The 'Available Destinations' section lists 'getDailyRateNormal' and 'getDailyRateHolidays'.

Start Date	End Date	Destination
Dec 23, 2005 8:00 PM	Jan 8, 2006 8:00 PM	getDailyRateHolidays
Nov 23, 2005 8:00 PM	Nov 28, 2005 8:00 PM	getDailyRateHolidays

## ■ Rule Set

The screenshot shows the configuration for a Rule Set. It includes sections for 'Interface', 'Variables', and 'Rules'. The 'Interface' section has a table for Input(s) and Output(s). The 'Variables' section has a table for Name and Type. The 'Rules' section has a table for Name, Presentation, and Action.

Name	Type
Input(s)	input1
Output(s)	output1

Name	Type
FreeGift	LineItem

Name	Presentation	Action
Rule1		output1 = copyBO( input1)
Rule2		output1.orderTotal = input1.orderTotal * 0.85 output1.lineItems.add( FreeGift) return
Rule3		output1.orderTotal = input1.orderTotal * 0.90 return

## ■ Decision Table

The screenshot shows the configuration for a Decision Table. It includes sections for 'Interface', 'Initialize', and 'Table'. The 'Table' section has a table for Conditions and Actions.

Conditions	Actions
input1.custStatus == "gold"	input1.orderTotal * 0.85
*silver	input1.orderTotal * 0.90
Otherwise	input1.orderTotal * 1

# Business Rules – Logical Organization

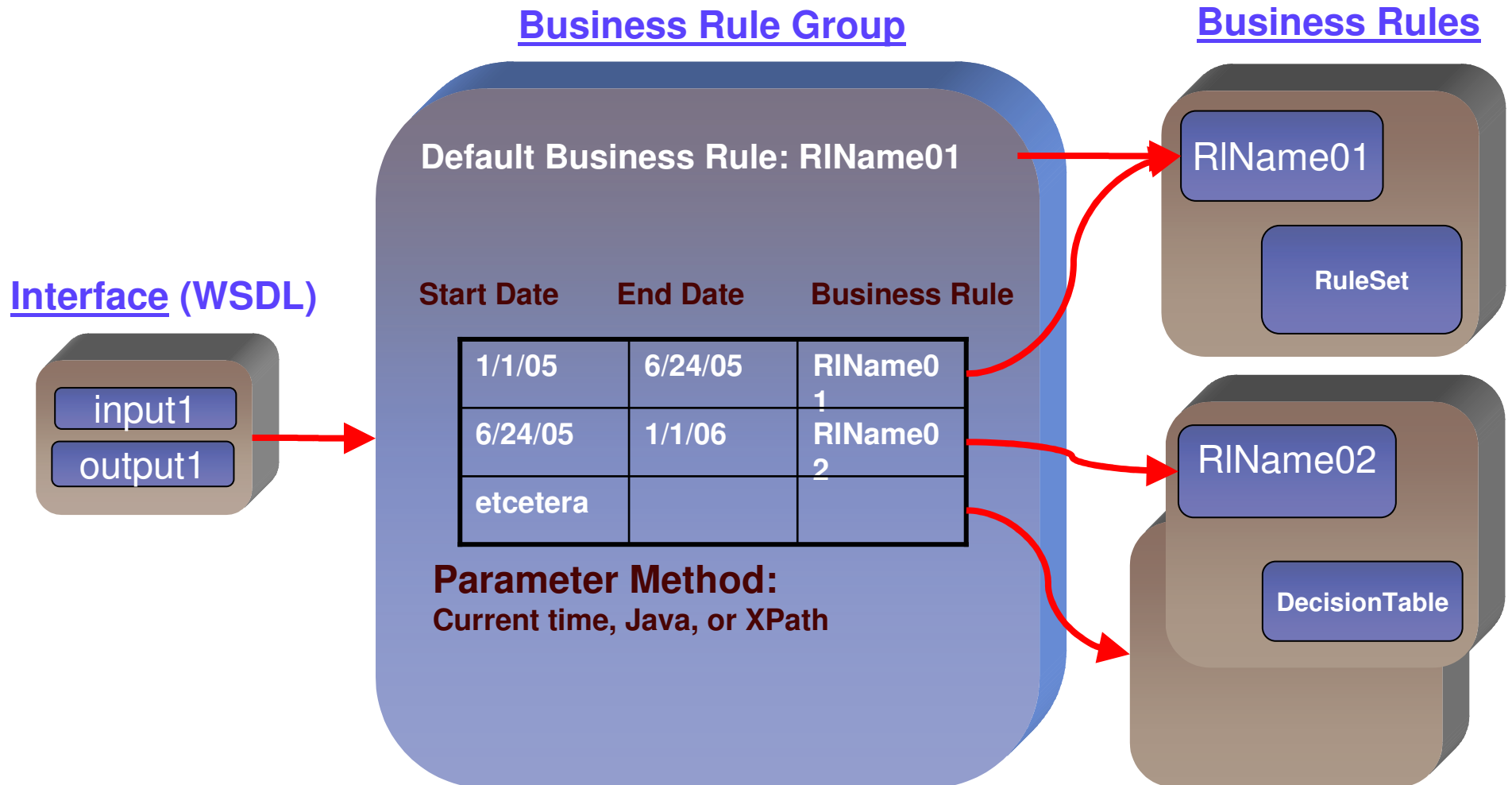

# Business Rules – Roles - Tooling

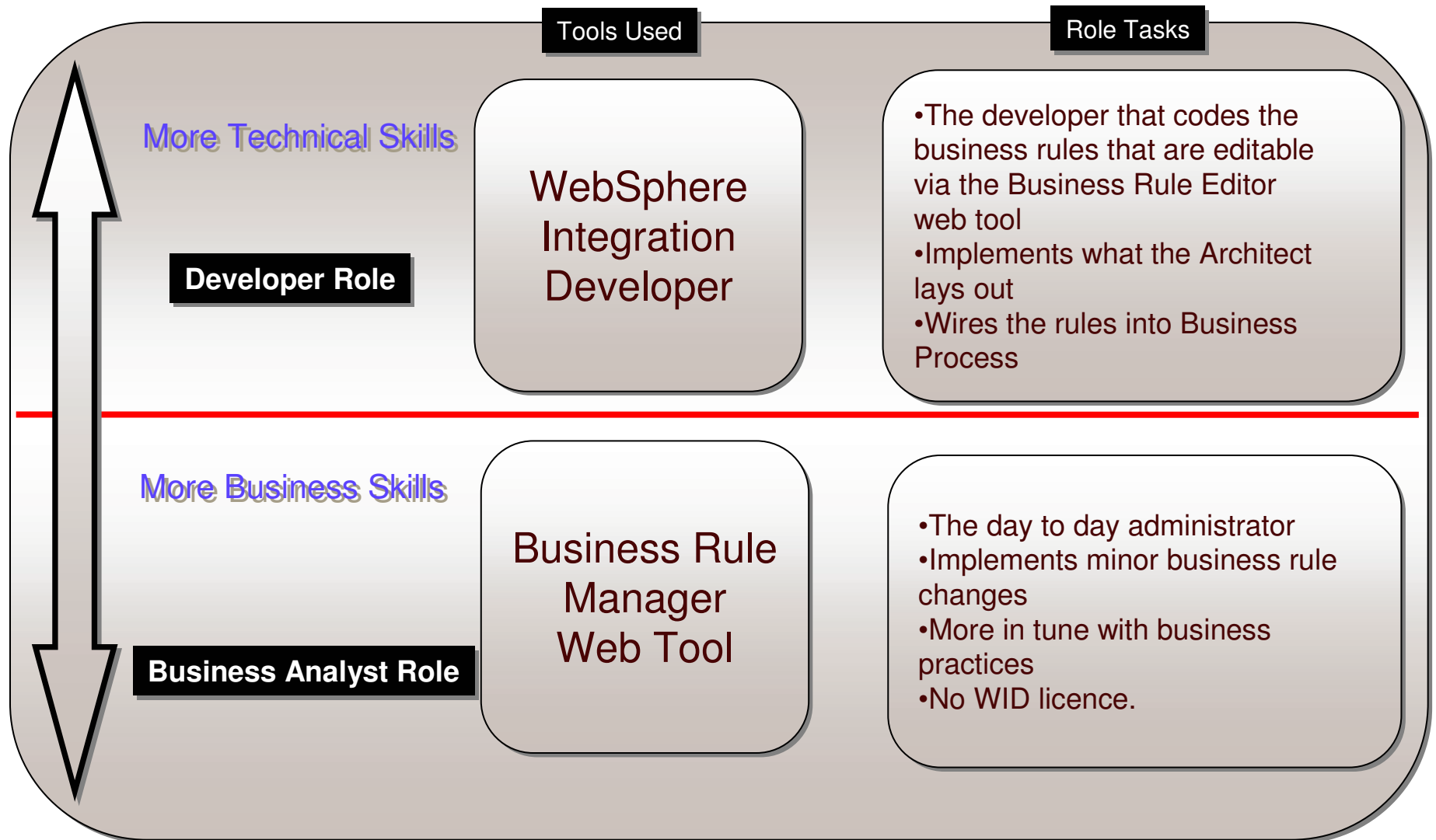

# Supporting Services – Transformation summary

- **Business Object Maps**
  - Translate one Business Object into another
- **Relationships**
  - Maintain Key Relationships for Business Data
- **Interface Maps**
  - Translate one interface into another
  - For Interfaces semantically identical but not syntactically
- **Selector**
  - Invoke different component based on time
  - All components have the same interface
- **Mediation**
  - Implementation of mediation logic



# Transformations

*Mediate between different service representations*

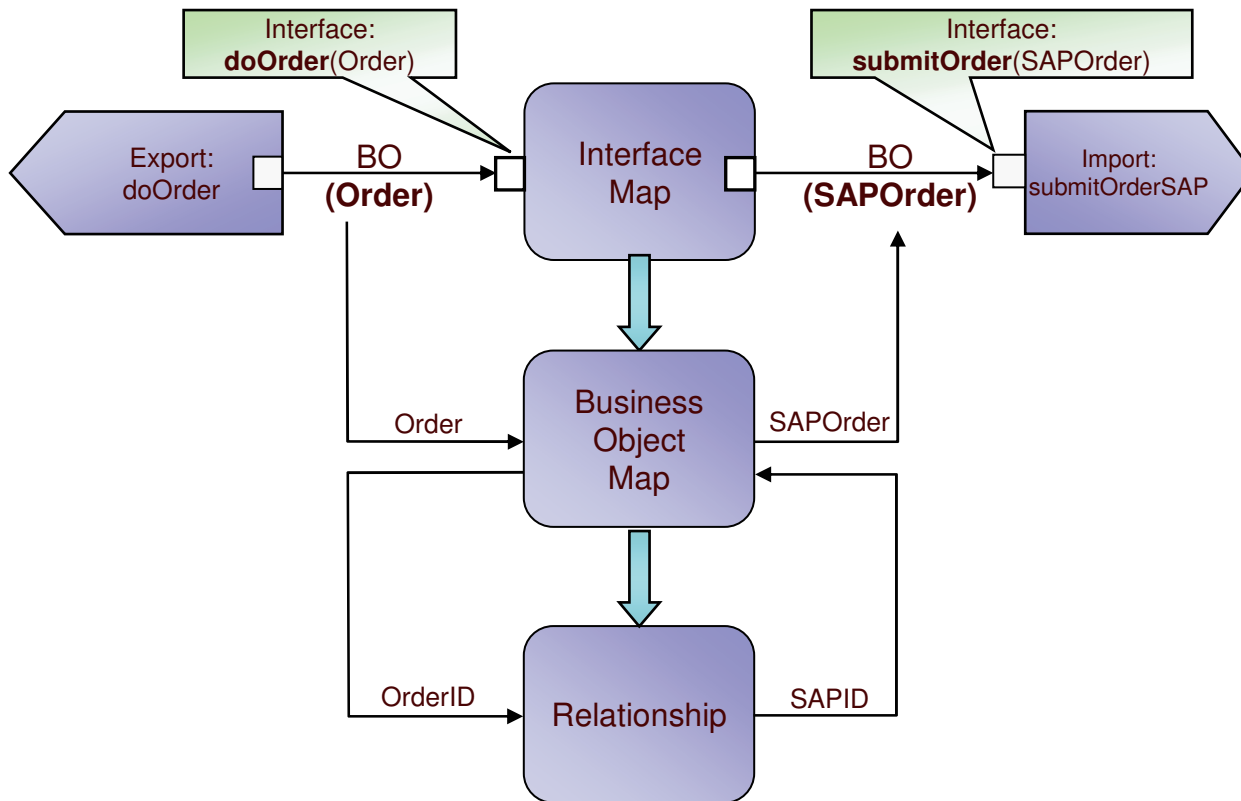

**Interface Maps**  
 Translate interface operations  
 doOrder ↔ submitOrder

**Business Object Maps**  
 Translate business object formats  
 Order ↔ SAPOrder

**Relationships**  
 Correlate business object identities  
 OrderID ↔ SAPID

## Transformation – Maps

- **Map Service is a ‘system’ Service**
- **Graphically convert one Business Object into another**
- **Mapping Functions**
  - Move, Extract , Join
  - Relationship Call
  - Assign
  - Submap
  - Custom
    - Activity Editor
    - Java Code

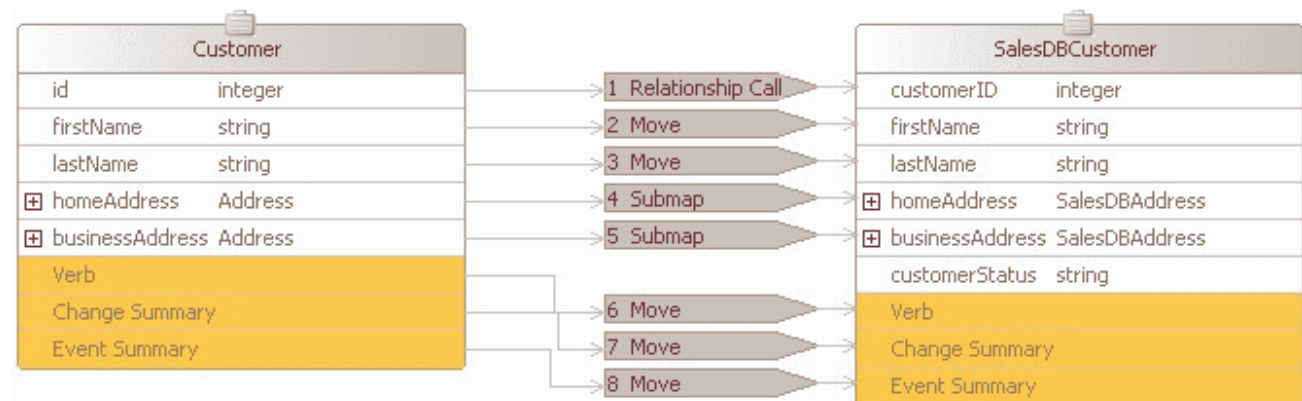



# Interface Transformation as a SCA component

## Interface Transformation

**Interface:** PSFTInterface  
**Operation:** SubmitProduct( PsftProductCategory )

**Interface:** CleansePublish  
**Operation:** process( ProductCategory )

Interface

Reference

## Parameter Mapping

PsftProductCategory	
eis1Product	PsftProduct
ID	string
description	string
pRODGRPTYPE	string
eFFDT	date
dESCR	string
eFFSTATUS	string
dESCRSHORT	string
gLOBALFLAG	string

ProductCategory	
ID	integer
shortDescription	string
longDescription	string
Product	Product

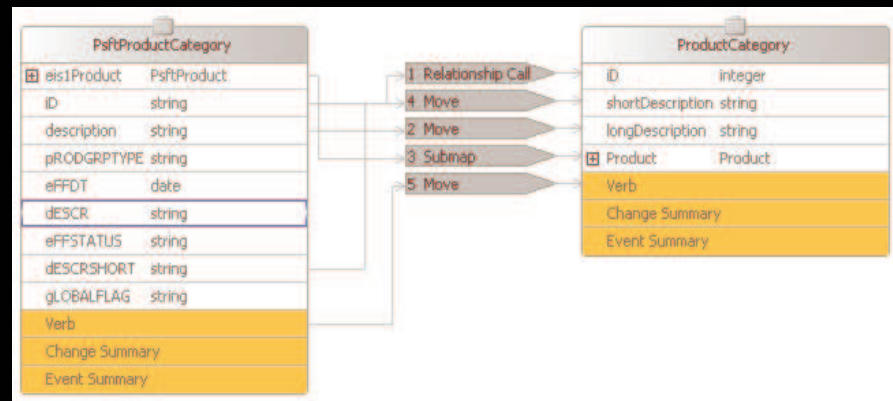

## Transformation – Relationship Service

- **Relationship Service is a ‘system’ Service**
- **Relationship Data stored in a database**
- **Two types of Relationships:**
  - Identity Relationships
    - Customer ID, Order ID, ...
  - Lookup Relationship
    - 1 = AL = Alabama, 2 = AK = Arkansas, 3 = AR = Arizona, ...
    - 1 = Monday, 2 = Tuesday, 3 = Wednesday, ...



Dynamic Service Selection

# Selector

- **Client**
  - makes a call to the Selector Component
- **Selector Component**
  - chooses which target destination to invoke using a declared selection implementation
- **Destination(s)**
  - for each operation on the Selector Component are associated with the Selector Component
- **Web-based Administration**

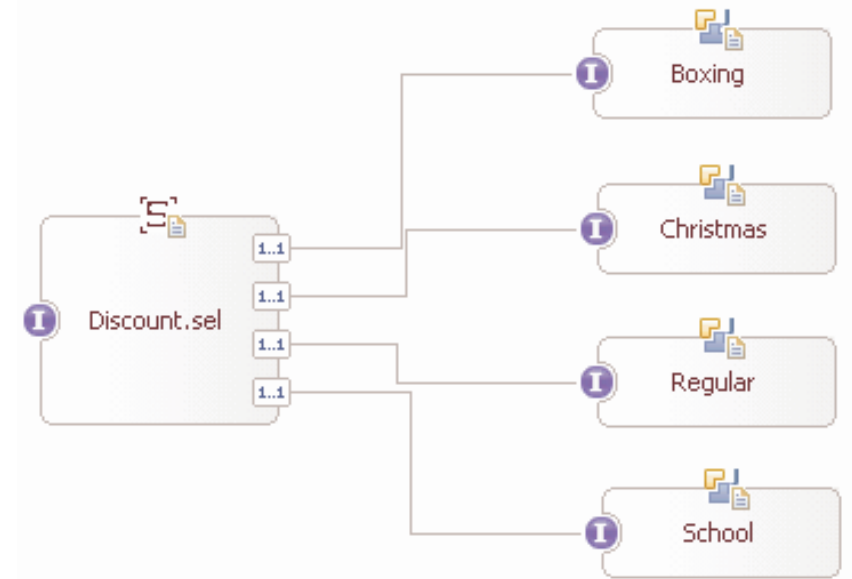
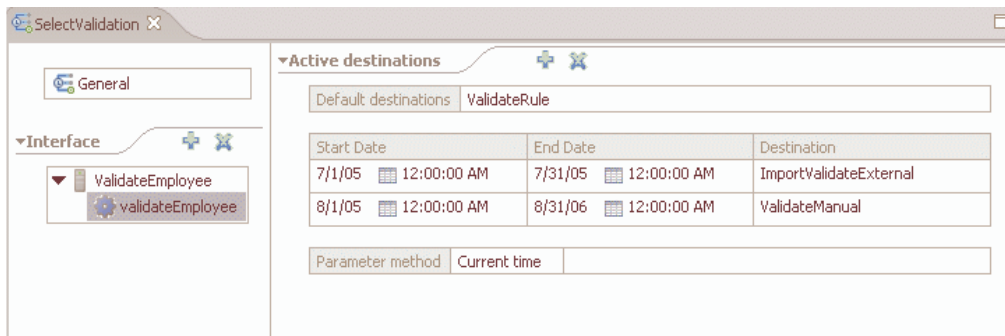

# ESB Mediation Flow

Mediation  
(ESB)

- **Provide the Implementation of mediation “logic”**

- “flows” that operate on messages/events as they are processed by the system
- Operate on both One-Way and Request-Response interactions
- In a Mediation Module

- **Pre-Supplied primitives allow flows to be visually composed**

- XSLT Transformation
- Message Logger / Message Filter
- Fail /Stop
- Database Lookup
- Custom Mediation
- CEI Emitter
- WSRR integration (static/dynamic)
- Dynamic endpoint selection

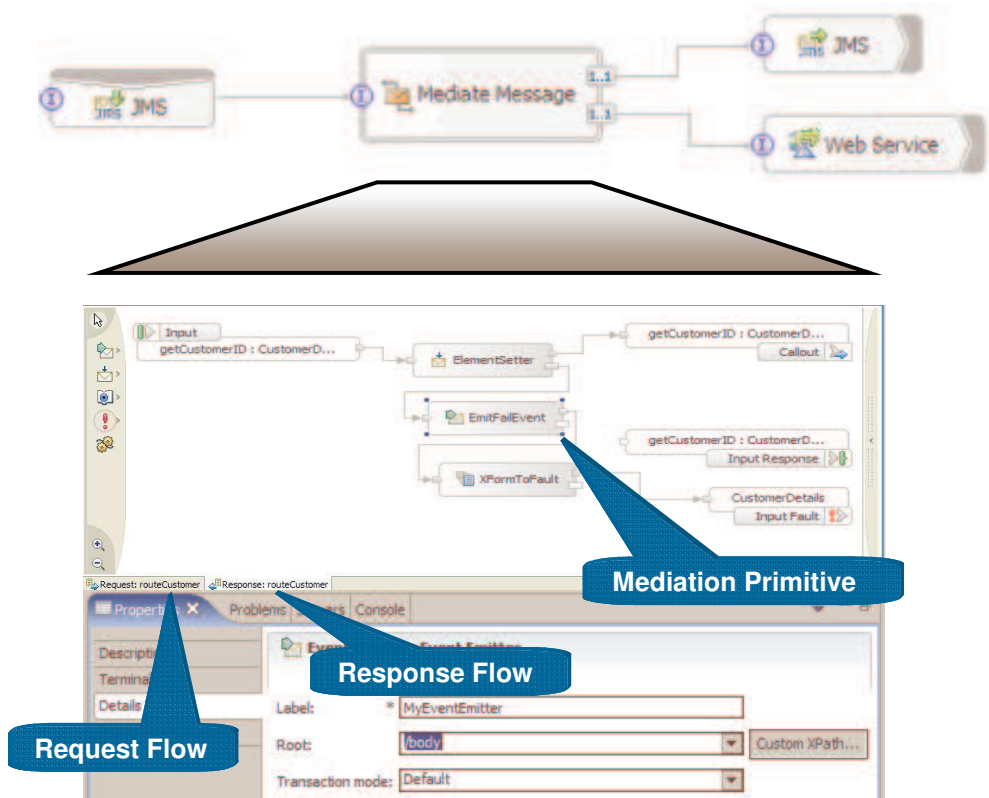

## Common Connectivity: Enterprise Service Bus

**WebSphere Enterprise Service Bus is an integral part of WebSphere Process Server and provides a connectivity infrastructure for integrating applications and services.**

*An ESB performs the following between requestor and service*

- **ROUTING** messages between services
- **CONVERTING** transport protocols between requestor and service
- **TRANSFORMING** message formats between requestor and service
- **HANDLING** business events from disparate sources



# WebSphere Integration Developer v6

- Reduced complexity
  - Provide a layer of abstraction over the J2EE programming model
- Solution building blocks based on integration-level concepts and patterns
  - Process Choreography, Mediation, Relationships, Business Rules, etc...
- Not J2EE Artifacts
  - EJBs, RARs, EARs, WARs, etc..
- Application assembly
  - Enable solution assembly from components
- Test and debug: Integration test client and integration debuggers

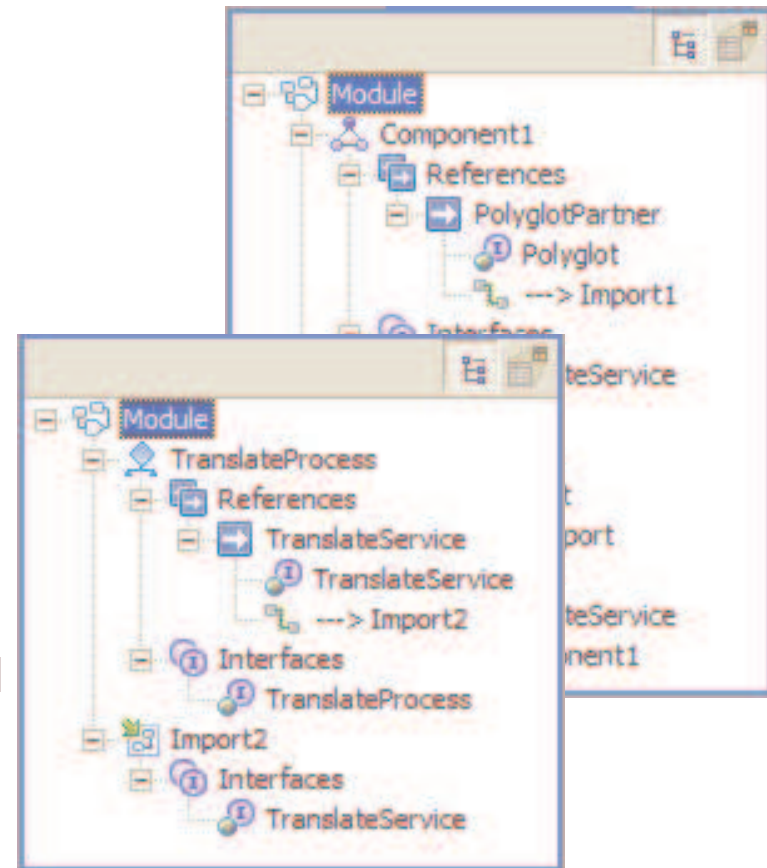

# Build & Assemble

## Visual Tools for building Components

### Defining human tasks

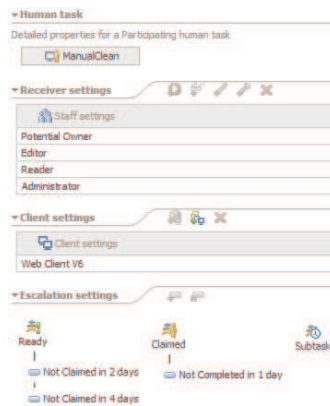

Human Task Editor

### Assemble Service Components



### Defining business rules

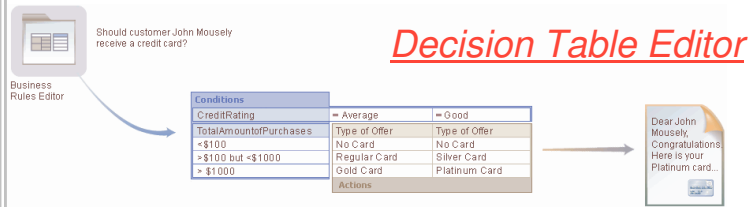

Decision Table Editor

### Creating Business Processes

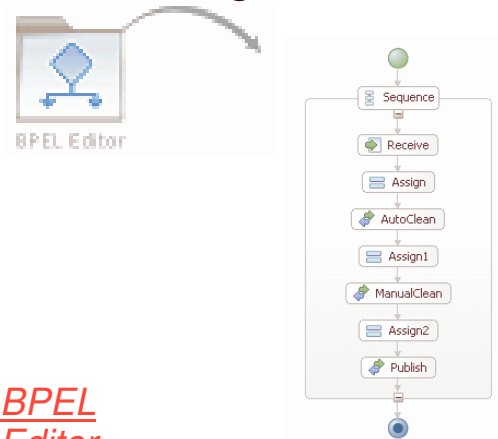

BPEL Editor

...and more

# Test & Debug

## Visual Tools for testing your composite solutions

### Testing composite application

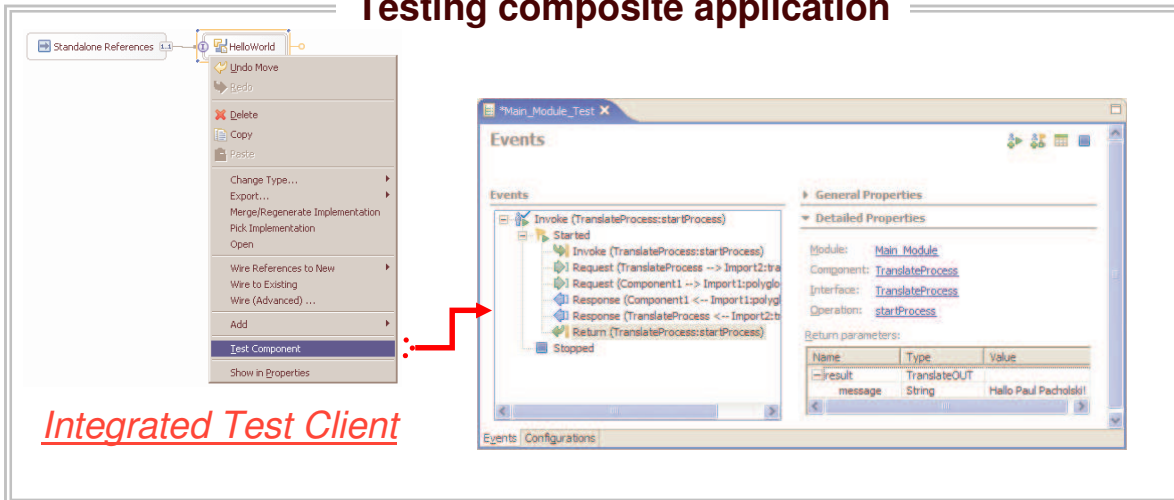

*Integrated Test Client*

### Debugging composite application

- Set breakpoints
- Jump in to source code
- Process, Visual Snippets, Business Maps, Business Rules, State Machines

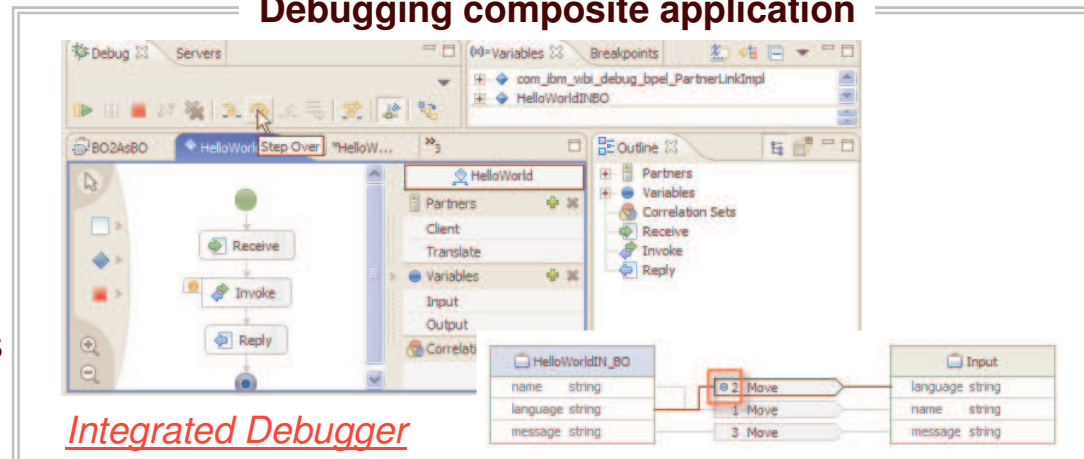

*Integrated Debugger*



# Business Driven Development – Roles and Tools ...

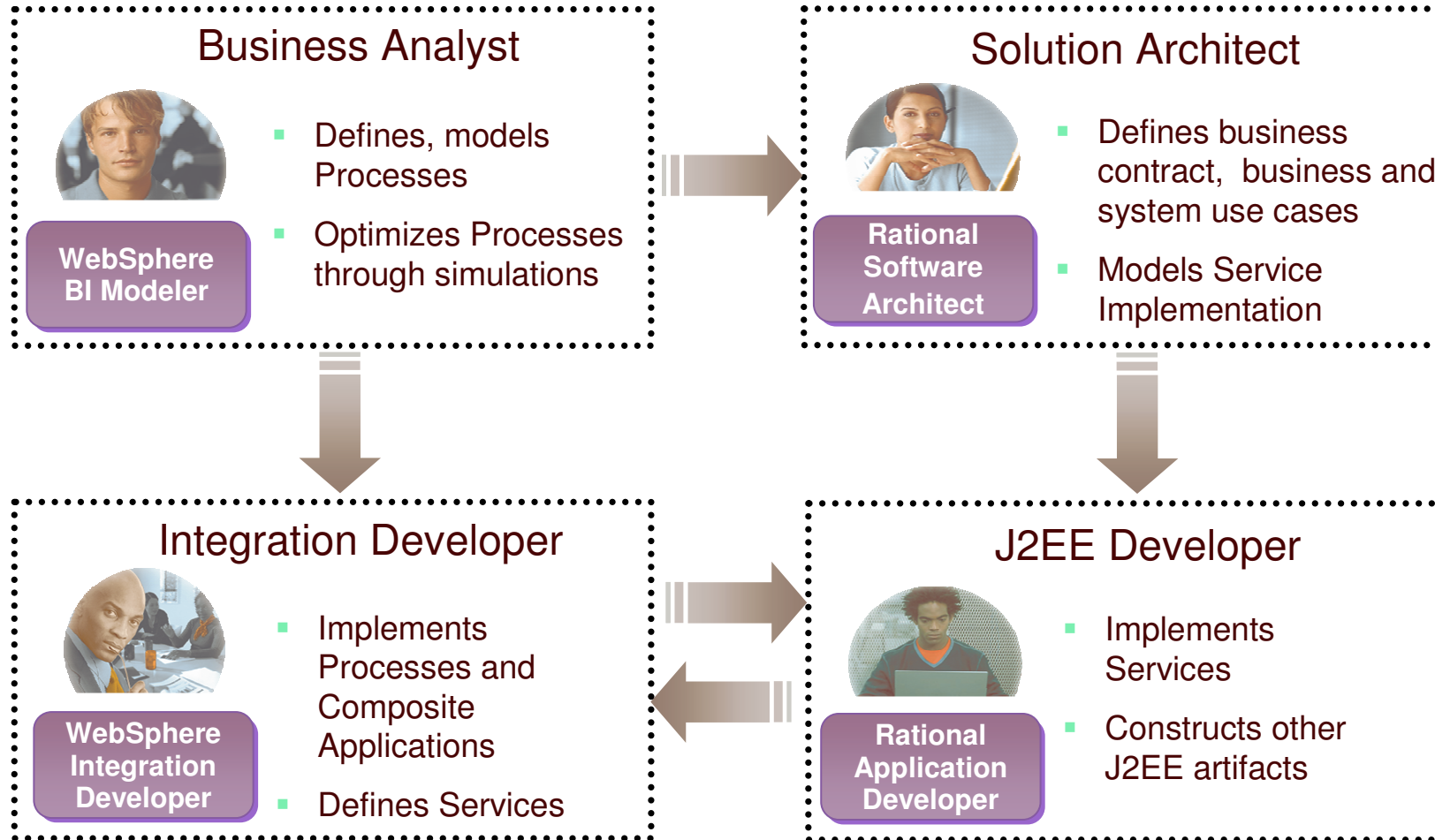

# Agenda

- **Concepts**
- **SOA & BPM Introduction**
- **Model**
- **Assemble & Deploy**
- **Manage**

# Manage - View and modify your business in real time

- Report on how the business is performing as measured against defined objectives – a scorecard view implemented through Key Performance Indicators
  - Eliminate redundancies or inefficiencies
  - Identify bottlenecks – balance workloads
  - Reduce latencies
  
- Track and modify business process flows
  - Eliminate redundancies or inefficiencies
  - Identify bottlenecks – balance workloads
  - Reduce latencies
  
- Intervene in deployed processes
  - Set situational triggers and notifications
  - Dynamically respond to these alerts
  
- Monitor business process metrics
  - Cost, time, resources
  - Make modifications based upon simulation data sent back to the WebSphere Business Modeler
  
- Mitigate risks by letting the WebSphere Business Monitor provide you with the relevant real-time data required run your business

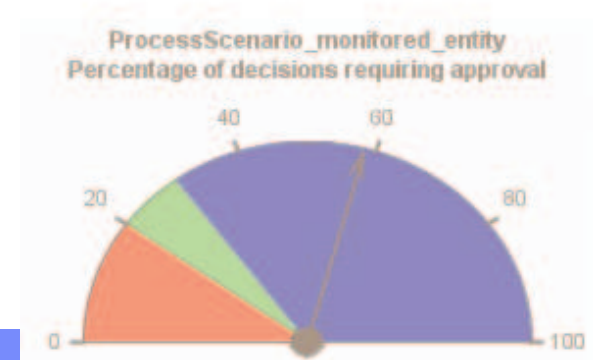
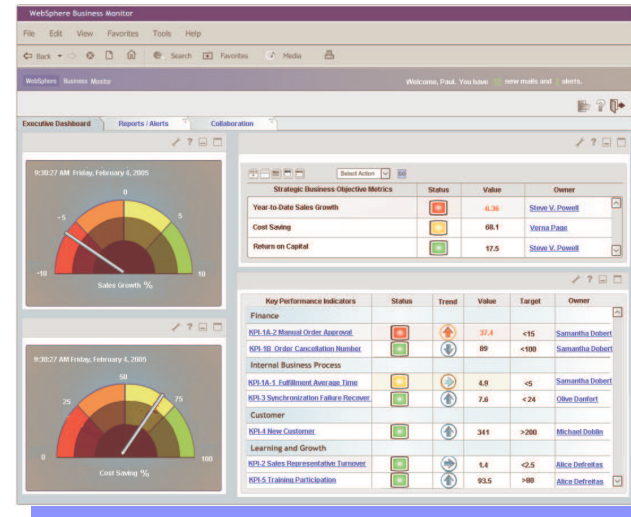

# WebSphere Business Monitor v6



- Open standard event infrastructure – Common Base Event (CBE)
- Monitoring support for IBM and non-IBM Monitoring support for solutions that emit CBE's
- WB Modeler support of KPI definitions and Eclipse based Monitor Measure Editor toolkit
- Key Features
  - Manage in flight processes
    - Monitor executing processes (i.e. Status, duration, cost, execution path, inspect process instance data)
    - Administer process instances (i.e. Start/Stop, transfer work items)
    - Export actual process data to Modeler for process re-engineering
  - Monitor the Business Performance of active processes
    - Business measures and KPIs calculated from live process data
  - Detect Business Situations and take action
    - Notifications sent for manual response: Email, Pager, SMS messages (future)
    - Invoke automated responses: a BPEL process, a Web Service
  - Gather Business Intelligence from collected process data with the ability to
    - Analyze business metrics over time to identify trends
    - Discover previously hidden patterns using dimensional analysis
  - Render information in role-based dashboards and scorecards to provide actionable insight

# Business Activity Monitoring in 4 scenarios

	Modeler	WID / WPS	MMP / Monitor	
1. BAM for BPEL (w/ Modeler)	✓	✓	✓	
2. BAM for BPEL (w/o Modeler)		✓	✓	
3. BAM for the rest of us			✓	
4. General BPM	✓		✓	

# WebSphere Business Monitor Runtime Architecture

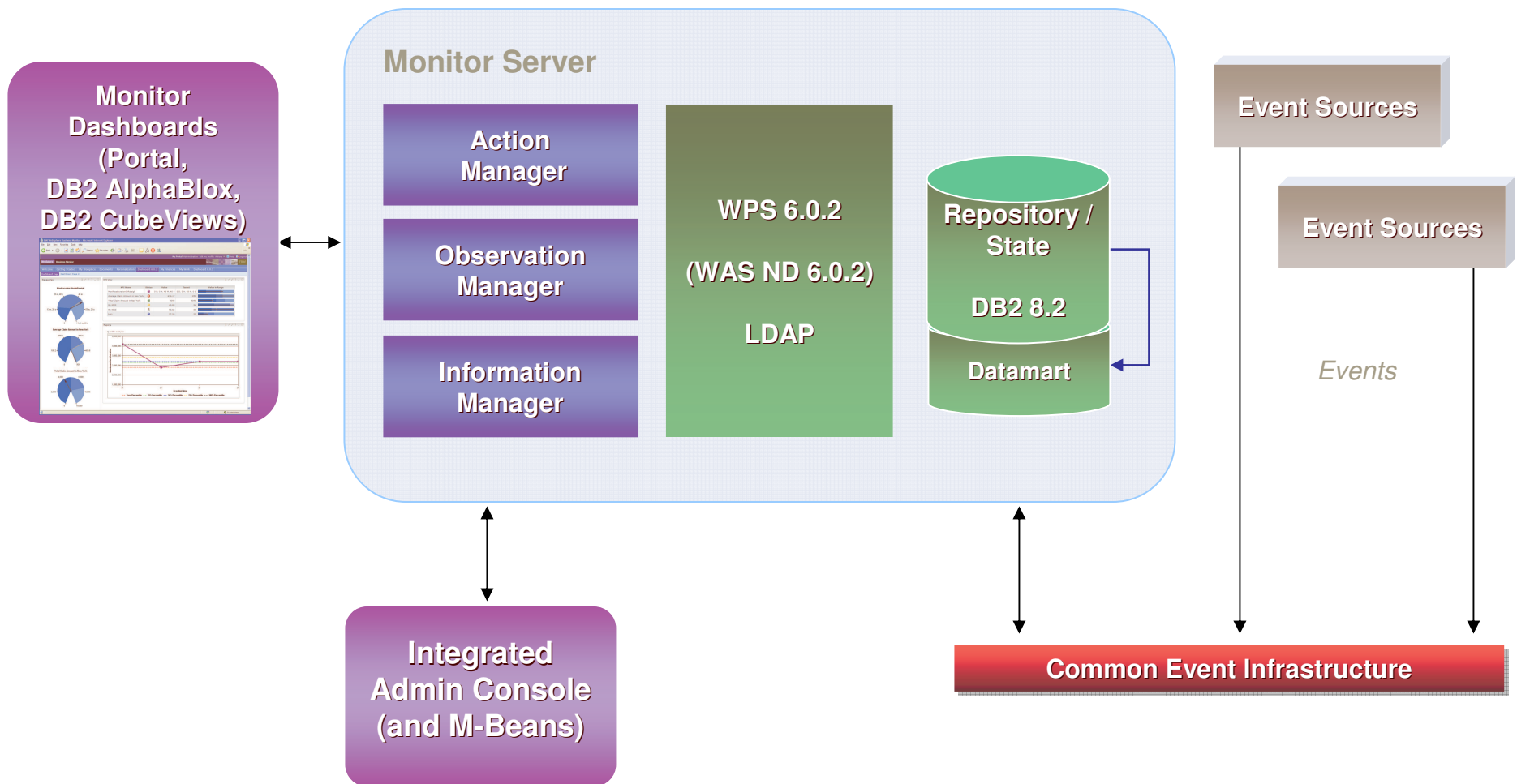

# Logical Architecture for Monitoring

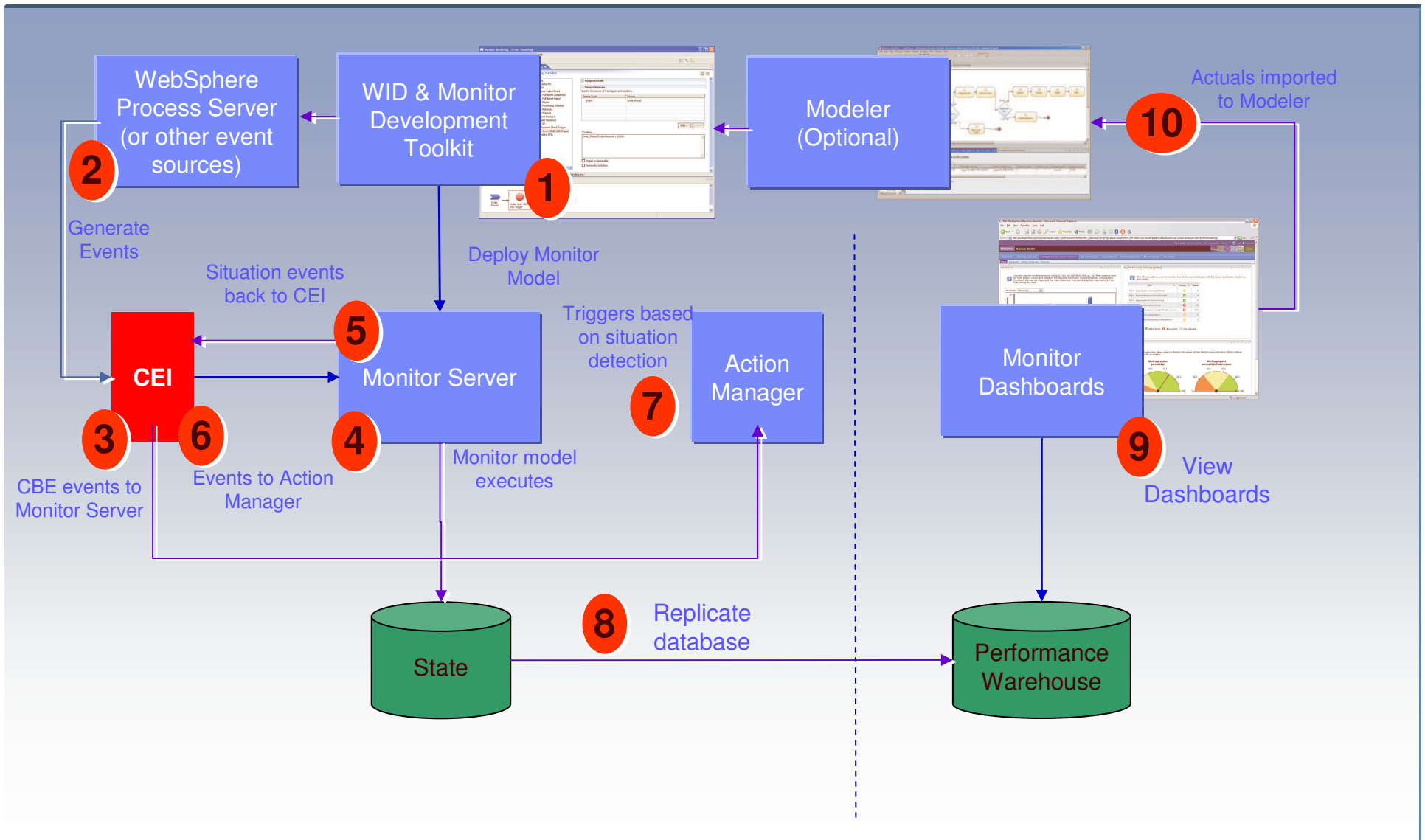

## References

- **IBM Education Assistant: Select WebSphere Software Products at**  
<http://www-306.ibm.com/software/info/education/assistant/>
- **Documentation**  
<http://www-306.ibm.com/software/integration/wps/library/infocenter/>
- **IBM Redbooks**  
<http://www.redbooks.ibm.com/>
- **White papers**
  - Introducing the WebSphere Integration Reference Architecture at [http://www-128.ibm.com/developerworks/websphere/techjournal/0508\\_simmons/0508\\_simmons.html](http://www-128.ibm.com/developerworks/websphere/techjournal/0508_simmons/0508_simmons.html)
  - WebSphere Process Server: IBM's new foundation for SOA at [http://www-128.ibm.com/developerworks/websphere/library/techarticles/0509\\_kulhanek/0509\\_kulhanek.html](http://www-128.ibm.com/developerworks/websphere/library/techarticles/0509_kulhanek/0509_kulhanek.html)
  - Building SOA solutions with the Service Component Architecture -- Part 1 at [http://www-128.ibm.com/developerworks/websphere/techjournal/0510\\_brent/0510\\_brent.html](http://www-128.ibm.com/developerworks/websphere/techjournal/0510_brent/0510_brent.html)



*Thank you!*