

University of Toronto

Term Test 2

Date - Nov 17, 2010

Duration: 1.5 hrs

ECE512 — Analog Signal Processing

Lecturer - D. Johns

ANSWER QUESTIONS ON THESE SHEETS USING BACKS IF NECESSARY

1. Both programmable and non-programmable calculators allowed.
 2. Equation sheet on last page of this test.
 3. **Only tests written in pen will be considered for a re-mark.**
 4. Grading indicated by []. Attempt all questions since a blank answer will certainly get 0.
-

Last Name: _____

First Name: _____

Student #: _____

Question	Mark
1	
2	
3	
4	
5	
Total	

(max grade = 25)

[5] **Question 1:** Answer the True [T] or False [F] questions below by **circling** the correct answer. Each correct answer is worth 0.5 marks.

- T F If a random voltage signal with a **mean-squared** value of 2 is applied to a 1 ohm resistor, the power dissipated is 2 watts.
- T F A random signal with a white noise spectrum could have a probability density function (pdf) which is Gaussian, Uniform or some other pdf.
- T F A random signal with a Gaussian pdf will always have a white noise spectrum.
- T F The 1/f noise tangent principle is used to find the components in a circuit which contribute the most amount of noise.
- T F For a given filter response, to reduce noise generally requires more power dissipation.
- T F When upsampling a discrete-time signal, there is no concern about aliasing.
- T F The $\sin(x)/x$ response of a sample-and-hold has zero gain at $f_s/2$, f_s , $3f_s/2$, $2f_s$, ...
- T F Advance clocks are used in switched-capacitor circuits to give more settling time.
- T F In an oversampled D/A converter with a 1 bit quantizer, the quantizer is realized using a **analog** comparator.
- T F In an oversampled D/A converter with a 1 bit quantizer, the quantizer is realized using a **digital** comparator.

[5] Question 2:

a) Consider a white noise signal that has a root spectral density of $10 \text{ nV}/\sqrt{\text{Hz}}$ applied to the input of a first-order lowpass RC filter with $R = 1 \text{ k}\Omega$ and $C = 0.159 \mu\text{F}$. What is the total noise rms value at the output (include the thermal noise of the resistor). Assume $T = 300$.

b) The output noise of a circuit is measured to be -20 dBm around 100 kHz when a resolution bandwidth of 40 Hz is used. Find the root spectral density in $\text{V}/\sqrt{\text{Hz}}$. (dBm referenced to 50 ohms).

[5] Question 3: Using the bilinear transform, find an $H(z)$ to realize a second-order transfer-function with a dc gain of 5, a lowpass passband with $Q = 1$ in cont-time domain, and a -3 dB frequency at 2 kHz when the sampling rate is 50 kHz.

[5] **Question 4:** Consider the SC biquad filter shown below.

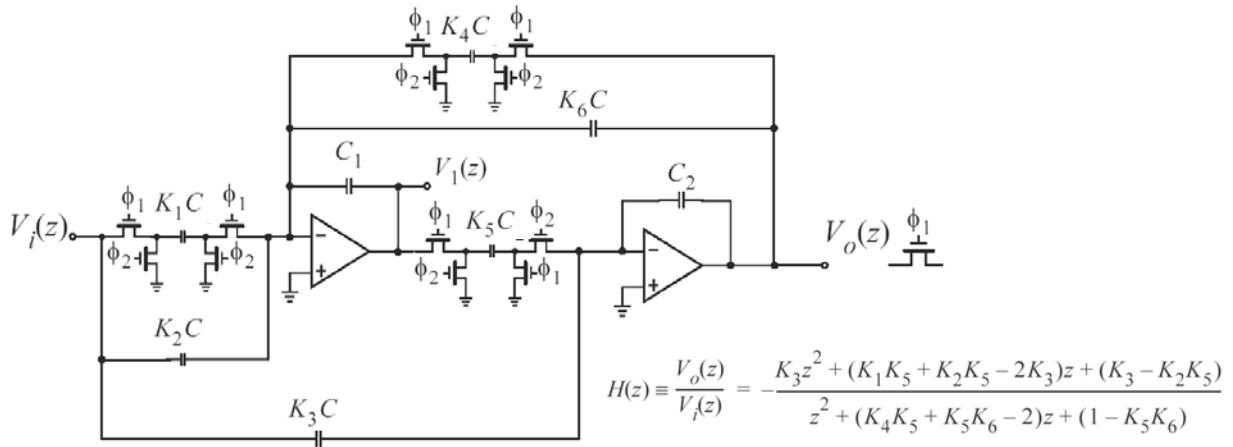

Given $C_1 = 1\text{pF}$ and $C_2 = 3\text{pF}$, find the values (in pF) for K_1C to K_6C so that

$H(z) = -\frac{0.288(z - 1)}{z^2 - 1.572z + 0.9429}$. Note that the subscript “j” on K_iC_j has been deleted on the

above figure so that you need to determine which integrating cap to reference the value to.

[5] **Question 5:** Given the error-feedback structure of a delta-sigma modulator shown below, replace the block $G(z) - 1$ by finding the appropriate transfer-function so that the noise transfer function equals $(1 - z^{-1})^2$. Show the overall implementation in terms of delay, gain, quantizer and adder blocks.

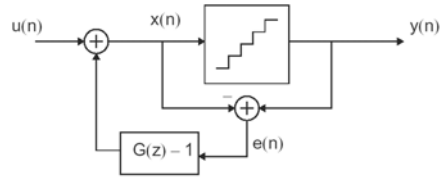

(blank sheet for scratch calculations)

ECE512

Analog Signal Processing

Equation Sheet

Constants: $k = 1.38 \times 10^{-23} \text{ JK}^{-1}$; $q = 1.602 \times 10^{-19} \text{ C}$; $\epsilon_0 = 8.854 \times 10^{-12} \text{ F/m}$; $V_T = kT/q \approx 26 \text{ mV}$ at $300 \text{ }^\circ\text{K}$;

General: $h(t)$ is impulse response of LTI system; $H(s)$ is the Laplace transform of $h(t)$

$$H(j\omega) = |H(j\omega)|e^{j\phi(\omega)}; T_d(\omega) = -\frac{d\phi(\omega)}{d\omega}; |H(j\omega)|_{\text{dB}} = 20 \log |H(j\omega)|; H(s) = \frac{a_m s^m + \dots + a_0}{s^N + b_{n-1}s + \dots + b_0}; |H(j\omega)|^2 = H(s)H(-s)|_{s=j\omega} = H(j\omega)H(-j\omega);$$

General Lowpass: $|H(j\omega)|^2 = A_0^2/(1 + F(\omega^2))$;

Butterworth: $F(\omega^2) = \epsilon^2 \left(\frac{\omega}{\omega_p}\right)^{2N}$; $A_{\text{max}} = 20 \log \sqrt{1 + \epsilon^2}$; $A_{\text{min}} \leq 10 \log \left[1 + \epsilon^2 \left(\frac{\omega_s}{\omega_p}\right)^{2N}\right]$; Poles lie on circle of radius $\omega_p(1/\epsilon)^{1/N}$ spaced apart by π/N with first angle being $\pi/(2N)$

Chebyshev: (for $\omega_p = 1$); $F(\omega^2) = \epsilon^2 C_N^2(\omega)$; $C_N(\omega) = \cos(N \cos^{-1}(\omega))$ $|\omega| \leq 1$; $C_N(\omega) = \cosh(N \cosh^{-1}(\omega))$ $|\omega| \geq 1$;

$$C_{N+1}(\omega) = 2\omega C_N(\omega) - C_{N-1}(\omega); A_{\text{max}} = 20 \log \sqrt{1 + \epsilon^2}; A_{\text{min}} \leq 10 \log [1 + \epsilon^2 \cosh^2(N \cosh^{-1}(\omega_s/\omega_p))];$$

Second-order polynomial: $s^2 + (\omega_0/Q)s + \omega_0^2$; for $Q > 0.5$; poles complex at radius ω_0 and real part is $-\omega_0/(2Q)$;

Lowpass and highpass: peaking occurs if $Q > 1/\sqrt{2}$ and $\omega_{\text{max}} = \omega_0 \sqrt{1 - 1/2Q^2}$

Bandpass: for complex poles; peak occurs at ω_0 and has 3 dB bandwidth of ω_0/Q

LCR: $\omega_0 = 1/\sqrt{LC}$; $Q = \omega_0 CR$;

KHN Biquad: $RC = 1/\omega_0$; $2((R_1 \parallel R_2)/(R_1 \parallel R_2 + R_3)) = 1/Q$; $2((R_2 \parallel R_3)/(R_2 \parallel R_3 + R_1)) = k$;

Tow-Thomas Biquad: $RC = 1/\omega_0$; damping resistor is QR ; numerator is $-s^2 \left(\frac{C_1}{C}\right) - s \left(\frac{1}{C}\right) \left(\frac{1}{R_1} - \frac{r}{RR_3}\right) - \frac{1}{RR_2 C^2}$;

Noise: noise equivalent bandwidth $= (\pi/2)f_{3\text{dB}}$; $V_R^2(f) = 4kTR$; $I_D^2(f) = 2qI_D$; $r_d = (kT)/(qI_D)$; $V_C^2 = (kT)/C$;

Discrete-Time: $X_s(s) = \sum x_c(nT)e^{-snT}$; $X(z) = \sum x_c(nT)z^{-n}$; $p = (z-1)/(z+1)$; $z = (1+p)/(1-p)$; $\Omega = \tan(\omega/2)$;

Switched-Cap: $R_{\text{eq}} = T/C$; $Q_{\text{CH}} = -WLC_{\text{ox}}(V_{\text{GS}} - V_t)$;

Data Converters: $B_{\text{in}} = b_1 2^{-1} + \dots + b_N 2^{-N}$; $V_{\text{LSB}} = V_{\text{ref}}/2^N$; $V_{\text{out}} = V_{\text{ref}} B_{\text{in}}$; $V_{\text{ref}} B_{\text{out}} = V_{\text{in}} + V_Q$; $|V_Q| \leq 0.5 V_{\text{LSB}}$;

$$V_{Q(\text{rms})} = V_{\text{LSB}}/\sqrt{12}; \text{SNR} = 6.02N + 1.76; E_{\text{off(D/A)}} = V_{\text{out}}/V_{\text{LSB}}|_{0..0}; E_{\text{off(A/D)}} = V_{0..01}/V_{\text{LSB}} - 0.5 \text{LSB}; \Delta t < 1/(2^N \pi f_{\text{in}});$$

$$E_{\text{gain(D/A)}} = (V_{\text{out}}/V_{\text{LSB}}|_{1..1} - V_{\text{out}}/V_{\text{LSB}}|_{0..0}) - (2^N - 1); E_{\text{gain(A/D)}} = (V_{1..1}/V_{\text{LSB}} - V_{0..01}/V_{\text{LSB}}) - (2^N - 2);$$

Oversampling: $\text{OSR} = f_s/(2f_0)$; $\text{SNR}_0 = 6.02N + 1.76 + 10 \log(\text{OSR})$; $\text{SNR}_1 = 6.02N + 1.76 - 5.17 + 30 \log(\text{OSR})$;

$$\text{SNR}_2 = 6.02N + 1.76 - 12.9 + 50 \log(\text{OSR}); S_{\text{TF}}(z) = H(z)/(1 + H(z)); N_{\text{TF}}(z) = 1/(1 + H(z))$$

$$T_{\text{avg}}(z) = \frac{1}{M} \sum_{i=0}^{M-1} z^{-i} = \frac{1}{M} \left(\frac{1 - z^{-M}}{1 - z^{-1}} \right); T_{\text{avg}}(e^{j\omega}) = \frac{\text{sinc}((\omega M)/2)}{\text{sinc}(\omega/2)}; |N_{\text{TF}}(e^{j\omega})| \leq 1.5 \text{ for 1-bit quantizer stability};$$

Bipolar transistors: $I_C = I_{\text{CS}} e^{V_{\text{BE}}/V_T}$; $g_m = I_C/V_T$; $r_e = \alpha/g_m = V_T/I_E$;

CMOS transistors: $K_n = 0.5 \mu_n C_{\text{ox}}(W/L)$; $I_D = 2K_n((V_{\text{GS}} - V_{\text{tn}})V_{\text{DS}} - (V_{\text{DS}}^2/2))$; $r_{\text{ds}} = (2K_n(V_{\text{GS}} - V_{\text{tn}}))^{-1}$;

$$I_D = K_n(V_{\text{GS}} - V_{\text{tn}})^2; g_m = 2K_n(V_{\text{GS}} - V_{\text{tn}}) = (2I_D)/(V_{\text{GS}} - V_{\text{tn}}); r_s = 1/g_m;$$

Ideal Transconductor: $i_o = G_m v_i$; **Bipolar Diff Pair:** $I_{C2} = I_1/(1 + e^{v_i/V_T})$;

CMOS Pair: $K_{\text{eq}} = (K_n K_p)/(\sqrt{K_n} + \sqrt{K_p})^2$; $V_{\text{t-eq}} = V_{\text{tn}} - V_{\text{tp}}$;

Dynamic Range: (all in dB or dBm) $ID_3 = I_{D3} - I_{D1}$; $OIP_3 = I_{D1} - ID_3/2$; $\text{SFDR} = (2/3)(OIP_3 - N_o)$;

$$\text{THD} = 10 \log((V_{h2}^2 + V_{h3}^2 + \dots)/V_f^2);$$