

## Data Converter Fundamentals

David Johns and Ken Martin  
University of Toronto  
(johns@eecg.toronto.edu)  
(martin@eecg.toronto.edu)



University of Toronto

slide 1 of 33

© D.A. Johns, K. Martin, 1997

## Introduction

- Two main types of converters

### Nyquist-Rate Converters

- Generate output having a one-to-one relationship with a single input value.
- Rarely sample at Nyquist-rate because of need for anti-aliasing and reconstruction filters.
- Typically 3 to 20 times input signal's bandwidth.

### Oversampling Converters

- Operate much faster than Nyquist-rate (20 to 512 times faster)
- Shape quantization noise out of bandwidth of interest, post signal processing filters out quantization noise.



University of Toronto

slide 2 of 33

© D.A. Johns, K. Martin, 1997

## Ideal D/A Converter

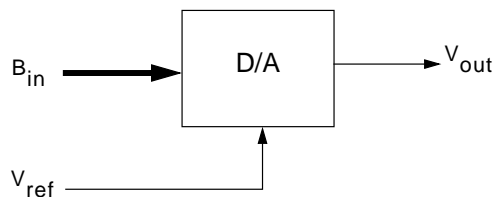

- $B_{in}$  defined to be an  $N$ -bit digital signal (or word)

$$B_{in} = b_1 2^{-1} + b_2 2^{-2} + \dots + b_N 2^{-N} \quad (1)$$

- $b_i$  equals 1 or 0 (i.e.,  $b_i$  is a binary digit)
- $b_1$  is MSB while  $b_N$  is LSB
- Assume  $B_{in}$  is positive — unipolar conversion



University of Toronto

slide 3 of 33

© D.A. Johns, K. Martin, 1997

## Ideal D/A Converter

- Output voltage related to digital input and reference voltage by

$$\begin{aligned} V_{out} &= V_{ref}(b_1 2^{-1} + b_2 2^{-2} + \dots + b_N 2^{-N}) \\ &= V_{ref} B_{in} \end{aligned} \quad (2)$$

- Max  $V_{out}$  is  $V_{ref}(1 - 2^{-N})$
- Multiplying DAC realized by allowing  $V_{ref}$  to be another input signal
- Ideal DAC has **well-defined values** (not same for A/D)



University of Toronto

slide 4 of 33

© D.A. Johns, K. Martin, 1997

### Ideal DAC Converter

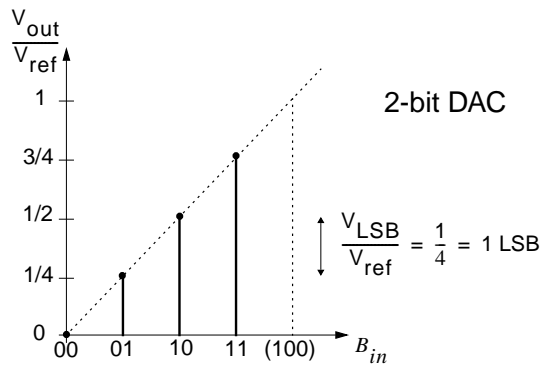

- $V_{LSB} \equiv \frac{V_{ref}}{2^N}$  and  $1 \text{ LSB} = \frac{1}{2^N}$



### Example

- An 8-bit D/A converter has  $V_{ref} = 5 \text{ V}$ .
- What is the output voltage when  $B_{in} = 10110100$ ?

$$B_{in} = 2^{-1} + 2^{-3} + 2^{-4} + 2^{-6} = 0.703125 \quad (3)$$

$$V_{out} = V_{ref} B_{in} = 3.516 \text{ V} \quad (4)$$

- Find  $V_{LSB}$ .

$$V_{LSB} = 5/256 = 19.5 \text{ mV} \quad (5)$$



### Ideal A/D Converter

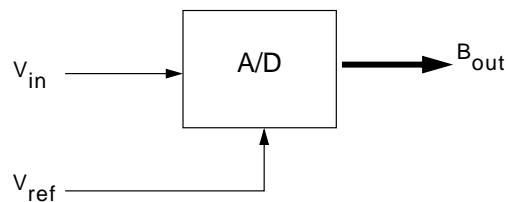

$$V_{ref}(b_1 2^{-1} + b_2 2^{-2} + \dots + b_N 2^{-N}) = V_{in} \pm V_x \quad (6)$$

where

$$-\frac{1}{2} V_{LSB} \leq V_x < \frac{1}{2} V_{LSB} \quad (7)$$



### Ideal A/D Converter

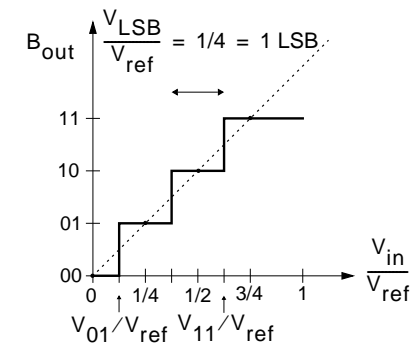

- A range of valid input values produces same digital output word — *quantization error*.
- No quantization error in D/A converter case.



## Ideal A/D Converter

- Transitions offset by  $0.5V_{LSB}$  so midpoints are same as D/A case

### Quantizer Overload

- Quantization error limited to  $\pm V_{LSB}/2$  otherwise quantizer is said to be “overloaded”.
- Overloading occurs when input signal is beyond one  $V_{LSB}$  of the two last transition voltages.
- In 2-bit example, input should be greater than  $-1/8 V_{ref}$  and less than  $7/8 V_{ref}$



## Quantization Noise

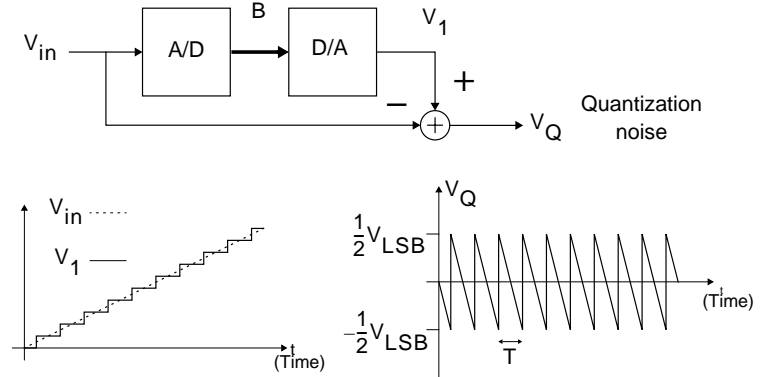

$$V_Q = V_1 - V_{in} \quad \text{or} \quad V_1 = V_{in} + V_Q \quad (8)$$



## Quantization Noise

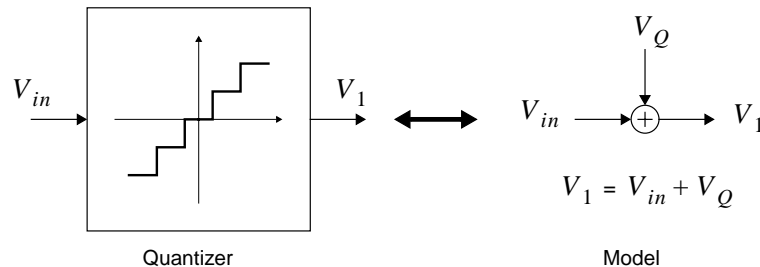

- Above model is exact — approx made when assumptions made about  $V_Q$
- Often assume  $V_Q$  is white, uniformly distributed number between  $\pm V_{LSB}/2$



## Quantization Noise

- Average of quantization noise is zero.
- Power of quantization noise can be shown to equal

$$V_{Q(rms)} = \frac{V_{LSB}}{\sqrt{12}} \quad (9)$$

- Each extra bit results in noise power decrease of 3dB
- Noise power is **independent** of sampling frequency
- If assume input signal is a sinusoid of peak amplitude of  $V_{ref}/2$

$$SNR = 20 \log \left( \frac{V_{in(rms)}}{V_{Q(rms)}} \right) = 20 \log \left( \frac{V_{ref}/(2\sqrt{2})}{V_{LSB}/(\sqrt{12})} \right)$$

$$SNR = 6.02N + 1.76 \text{ dB}$$



## Quantization Noise

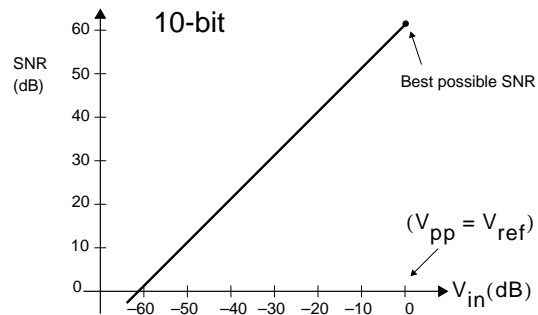

- SNR reaches max when input signal is max
- (might improve SNR if oversampling used)



University of Toronto

slide 13 of 33

© D.A. Johns, K. Martin, 1997

## Example

- A  $100\text{-mV}_{pp}$  sinusoidal signal is applied to an ideal 12-bit A/D converter for which  $V_{ref} = 5\text{ V}$ .
- Find the SNR of the digitized output signal.
- 
- First, find max SNR if full-scale sinusoidal waveform of  $\pm 2.5\text{ V}$  applied

$$\text{SNR}_{max} = 6.02 \times 12 + 1.76 = 74\text{ dB} \quad (10)$$

- Since input is only  $\pm 100\text{-mV}$  it is 28 dB below full scale, so SNR of digitized output is

$$\text{SNR} = 74 - 28 = 46\text{ dB} \quad (11)$$



University of Toronto

slide 14 of 33

© D.A. Johns, K. Martin, 1997

## Signed Codes

- Often need converters for both positive and negative signals — signed codes

### Sign Magnitude

- Neg numbers simply invert MSB

### 1's Complement

- Neg numbers invert all bits

### Offset Binary

- Assign 000... to most negative number and count up

### 2's Complement

- Invert MSB of offset binary case or ...
- Neg numbers are 1 LSB larger than 1's complement



University of Toronto

slide 15 of 33

© D.A. Johns, K. Martin, 1997

## Signed Codes

Number	Normalized number	Sign magnitude	1's complement	Offset binary	2's complement
+3	+3/4	011	011	111	011
+2	+2/4	010	010	110	010
+1	+1/4	001	001	101	001
+0	+0	000	000	100	000
(-0)	(-0)	(100)	(111)		
-1	-1/4	101	110	011	111
-2	-2/4	110	101	010	110
-3	-3/4	111	100	001	101
-4	-4/4			000	100

- 2's complement most common when doing signal processing



University of Toronto

slide 16 of 33

© D.A. Johns, K. Martin, 1997

## 2's Complement

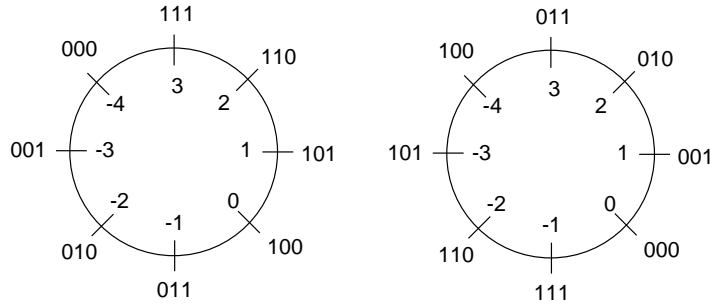

Offset Binary

2's Complement

- Each have *wrap-around* behaviour



## 2's Complement Benefits

- Addition of both positive numbers is done with simple addition (nothing extra needed)
- Subtraction of  $A - B$  done by complementing bits of  $B$  and adding LSB into carry-in of adder
- Can go above max as long as final result is within range (no overflow hardware needed)

### Example

- $2+3+(-4) = 1$   
 $010 + 011 + 100 = 101 + 100 = 001$
- Final result of 1 correct though temp result of -3 obtained



## Performance Limitations

- For D/A measure, use output voltage levels
- For A/D measure, use transition points (easier than midpoints)

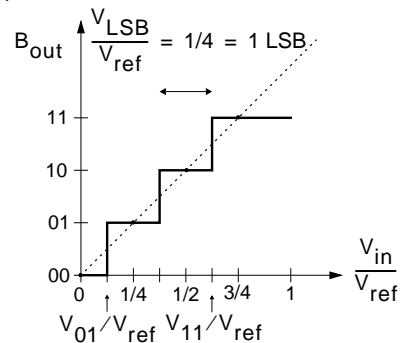

## Offset and Gain Error

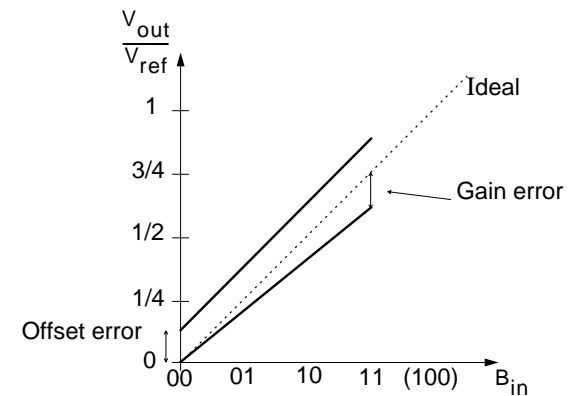

## Offset and Gain Error

- D/A converter — units of LSB:  $E_{\text{off}(D/A)} = \frac{V_{\text{out}}}{V_{\text{LSB}}}\Big|_{0\dots 0}$
- A/D converter — deviation of  $V_{0\dots 01}$  from  $1/2 \text{ LSB}$

$$E_{\text{off}(A/D)} = \frac{V_{0\dots 01}}{V_{\text{LSB}}} - \frac{1}{2} \text{ LSB} \quad (12)$$

- With gain error, set offset error to zero

$$E_{\text{gain}(D/A)} = \left( \frac{V_{\text{out}}}{V_{\text{LSB}}}\Big|_{1\dots 1} - \frac{V_{\text{out}}}{V_{\text{LSB}}}\Big|_{0\dots 0} \right) - (2^N - 1) \quad (13)$$

$$E_{\text{gain}(A/D)} = \left( \frac{V_{1\dots 1}}{V_{\text{LSB}}} - \frac{V_{0\dots 01}}{V_{\text{LSB}}} \right) - (2^N - 2) \quad (14)$$



## Resolution and Accuracy

### Resolution

- Number of distinct analog levels —  $n$   $N$ -bit resolution can resolve  $2^N$  distinct analog levels.

### Absolute Accuracy

- Difference between the expected and actual transfer responses — includes offset, gain and linearity errors

### Relative Accuracy

- After offset and gain errors removed — also called maximum integral nonlinearity error
- A 12-bit accuracy implies that the converter's error is less than the full-scale value divided by  $2^{12}$



## Resolution and Accuracy

- A converter may have 12-bit resolution with only 10-bit accuracy
- Another converter may have 10-bit resolution with 12-bit accuracy.
- Accuracy greater than resolution means converter's transfer response is very precisely controlled — better than the number of bits of resolution.

### Example

- A two bit D/A (resolution 2-bits) with output levels at 0.0, 1/4, 2/4, 3/4 is ideal (infinite bit accuracy since no errors)



## Integral Nonlinearity (INL) Error

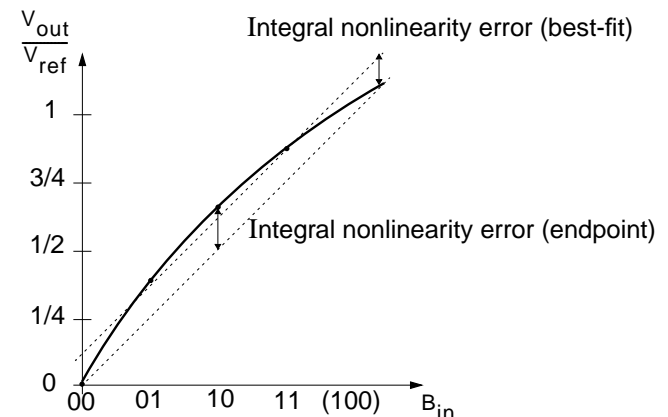

## INL Error

- After both offset and gain errors removed, *integral nonlinearity (INL) error* is deviation from a straight line.
- Can use endpoint or best fit straight lines — endpoint more conservative
- INL plotted for each digital word

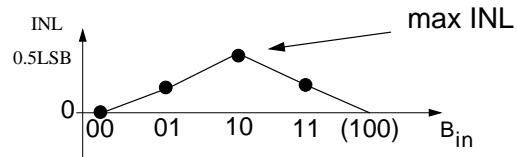

- Maximum INL also referred to as relative accuracy



## Differential Nonlinearity (DNL) Error

- Ideally, each step is 1 LSB away from adjacent level
- DNL defined as variation in step sizes from 1 LSB (once gain and offset errors removed)
- Example — Max DNL = 0.5 LSB has at least one step size which is either 0.5 LSB or 1.5 LSB
- As in INL error, DNL plotted for each digital word and max is maximum magnitude.

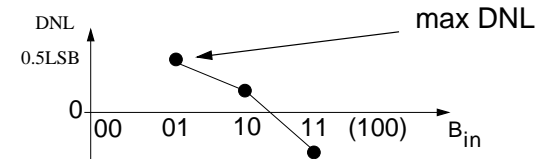

step size between 00 and 01 is 1.5 LSB  
step size between 10 and 11 is 0.7 LSB



## Monotonicity

### Monotonic D/A Converters

- Where output always increases as input increases — no negative slope in transfer-response
- Important for some control loop applications
- If max DNL < 1 LSB, converter is monotonic
- Can be monotonic and have DNL > 1 LSB
- If max INL < 0.5 LSB, converter is monotonic

### Missing Code A/D Converters

- Similar to monotonic but for A/D converter
- Increasing analog input skips some digital codes
- If max DNL < 1 LSB or max INL < 0.5 LSB, no missing codes



## Converter Speed

### A/D Conversion Time and Sampling Rate

- Conversion time — time for a single measurement
- Sampling rate — max sampling rate (typically inverse of conversion time)
- Note that converter might have *latency* due to pipelining

### D/A Settling Time and Sampling Rate

- Settling time — time for converter to settle to within a specified resolution (typically 0.5 LSB)
- Sampling rate — max rate (typically inverse of settling time)



## Sampling-Time Uncertainty

- Error due to variations in sampling time
- Consider full-scale sine wave:  $V_{in} = \frac{V_{ref}}{2} \sin(2\pi f_{in} t)$
- Rate of change is max at zero crossing
- If sampling time has variation  $\Delta t$ , then to keep  $\Delta V$  less than 1 LSB, require that

$$\Delta t < \frac{V_{LSB}}{\pi f_{in} V_{ref}} = \frac{1}{2^N \pi f_{in}} \quad (15)$$

- Example — 250 MHz sinusoidal signal must keep  $\Delta t < 5$  ps for 8-bit accuracy
- Same 5ps for 16-bit accuracy and 1 MHz sinusoid



## Dynamic Range

- Ratio of rms value of max amplitude input sinusoid to rms output noise plus distortion
- Can be expressed as N, **effective number of bits**

$$\text{SNR} = 6.02N + 1.76 \text{ dB} \quad (16)$$

- Often a function of freq of input signal (lower SNR as freq increases)  
— more realistic than only using INL and DNL
- Note, distortion of some converters not a function of input signal level
- Other converters (such as oversampling), distortion decreases as signal level decreases (similar to other analog circuits)



## Example

- 3-bit D/A converter,  $V_{ref} = 4$  V, with following values  
{0.011 : 0.507 : 1.002 : 1.501 : 1.996 : 2.495 : 2.996 : 3.491}

- 1 LSB —  $V_{ref}/2^3 = 0.5$  V
- Offset voltage is 11 mV resulting in

$$E_{off(D/A)} = \frac{0.011}{0.5} = 0.022 \text{ LSB} \quad (17)$$

- Gain error

$$E_{gain(D/A)} = \left( \frac{3.491 - 0.011}{0.5} \right) - (2^3 - 1) = -0.04 \text{ LSB} \quad (18)$$

- For INL and DNL errors, first remove both offset and gain errors



- Offset error removed by subtracting 0.022 LSB
- Gain error removed by subtracting off scaled values of gain error. Example — new value for 1.002 (scaled to 1 LSB) given by

$$\frac{1.002}{0.5} - 0.022 + \left(\frac{2}{7}\right)(0.04) = 1.993 \quad (19)$$

- Offset-free, gain-free, scaled values are  
{0.0 : 0.998 : 1.993 : 2.997 : 3.993 : 4.997 : 6.004 : 7.0} (20)

- INL errors — Since now in units of LSBs, given by difference between values and ideal values  
{0 : -0.002 : -0.007 : -0.003 : -0.007 : -0.003 : 0.004 : 0} (21)

- DNL errors — difference between adjacent values and 1 LSB  
{-0.002 : -0.005 : 0.004 : -0.004 : 0.004 : 0.007 : -0.004} (22)



### **Example**

- A full-scale sinusoidal is applied to a 12-bit A/D
- If fundamental has a normalized power of 1 W and remaining power is  $0.5 \mu\text{W}$ , what is the effective number of bits for the converter?

$$SNR = 6.02N_{eff} + 1.76 \quad (23)$$

- In this case, SNR given by

$$SNR = 10 \log\left(\frac{1}{0.5 \times 10^{-6}}\right) = 63 \text{ dB} \quad (24)$$

resulting in

$$N_{eff} = \frac{63 - 1.76}{6.02} = 10.2 \text{ effective bits} \quad (25)$$

